

First floor

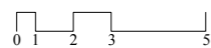

Gianfranco Sava / Yue Tam

104 105

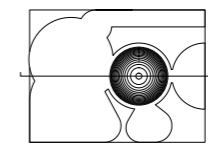
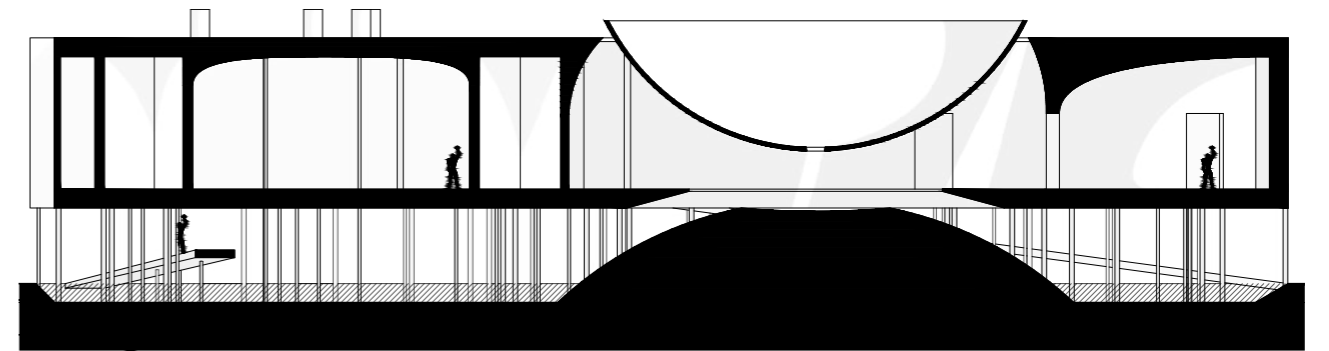

Section B-B'

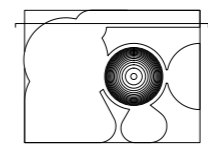
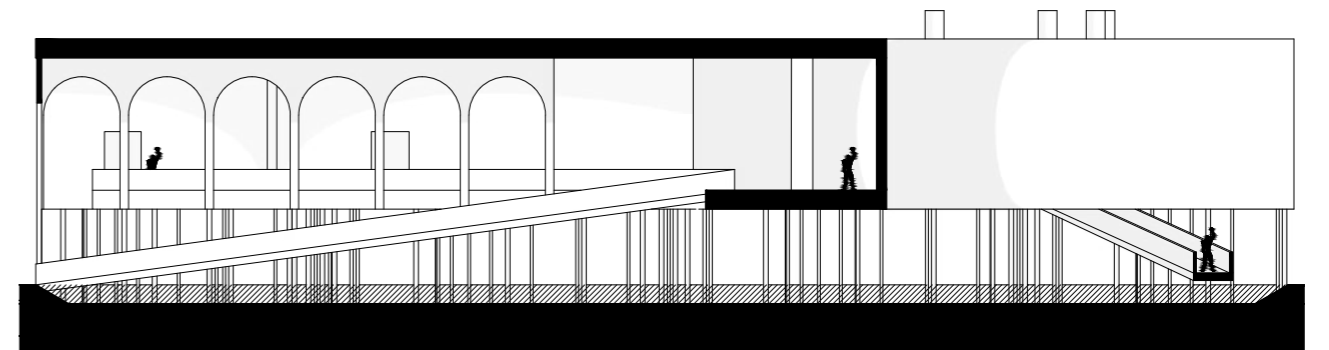

Section C-C'

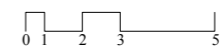

Gianfranco Sava / Yue Tam

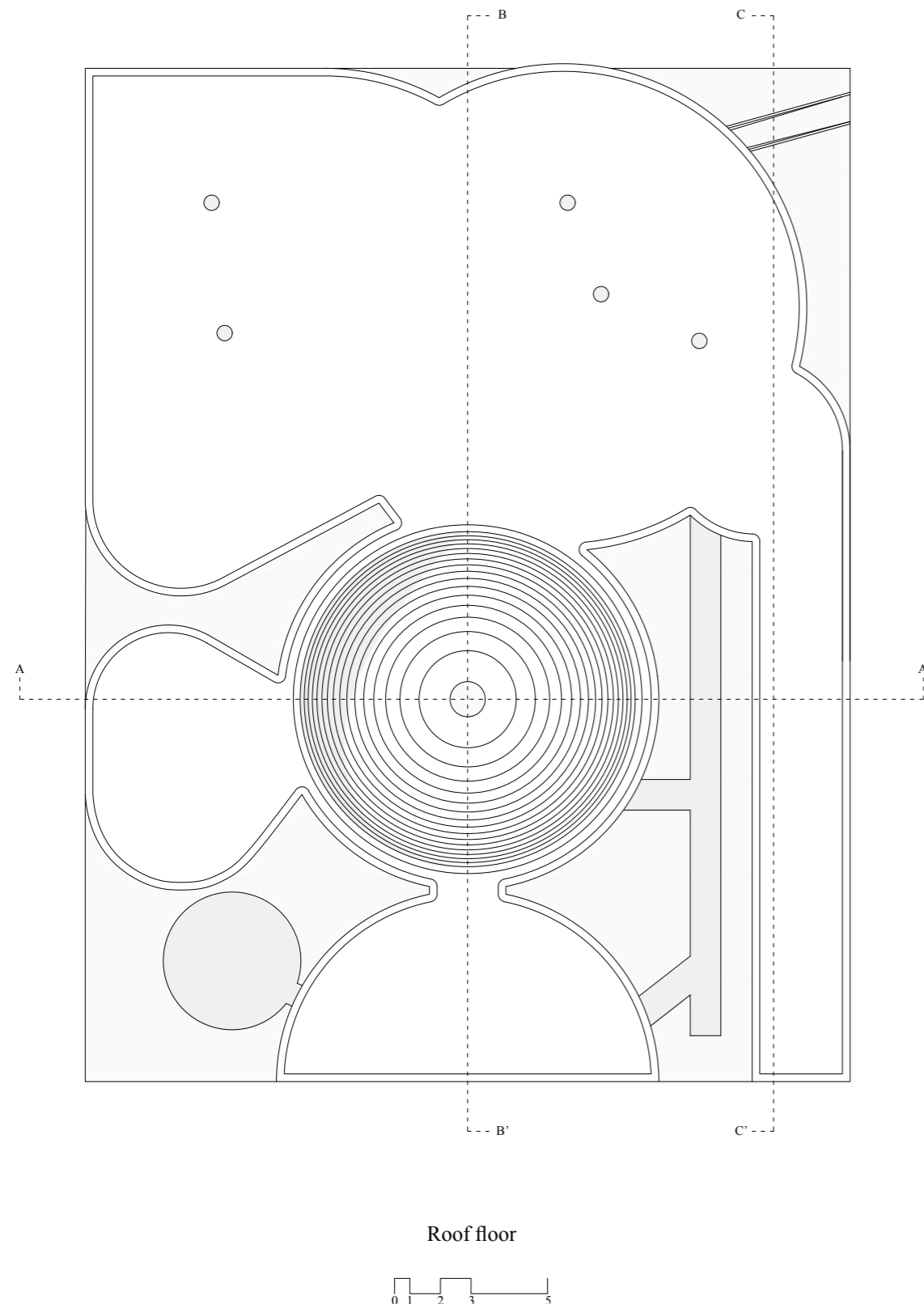

Gianfranco Sava / Yue Tam

dissolution which is progressive in so far as nature takes a hand and completes the disintegration which the artist started out to portray.

Today when ruins have become all too familiar and we appreciate their significance all too well, it is no longer possible to look upon the artificial ruin as no more than a harmless essay in the picturesque. If it were correct to regard such things as being no more than picturesque, then that would merely prove that our conception of **the picturesque was the mortal enemy of everything for which architecture stands**. No, the ruin shows us clearly, like a revealing dream, that even at this stage the death of architecture is already desired. Such an interpretation appears to find support in the fact that in the painting of that day we not only find portrayals of famous or imaginary ruins but – a monstrous omen – come across cases where the painter’s imagination has sought to envisage the ruins of buildings that were intact at the time. It is in this fashion, for instance, that Hubert Robert (1733- 1808), that most skilful painter of architectural subjects, treats the famous gallery of the Paris Louvre, while C. D. Friedrich shows us the suppositious ruins of Meissen Cathedral and of the Church of St. James in Greifswald. Here the painter's imagination verged on the prophetic. No other culture, no other epoch had till then envisaged these possibilities. Now in a world of real ruins we cannot but shudder as we contemplate these things.

That zero panorama seemed to contain *ruins in reverse*, that is – all the new construction that would eventually be built. This is the opposite of the “romantic ruin” because the buildings don’t fall into ruin after they are built but rather rise into ruin before they are built. This anti-romantic mise-en-scene suggests the discredited idea of time and many other “out of date” things... A Utopia minus a bottom, a place where the machines are idle, and the sun has turned to glass, and a place where the Passaic concrete plant (235 River Drive) does a good business in STONE, BITOIMINOUS, SAND, and CEMENT. Passaic seems full of “holes” compared to New York City, which seems tightly packed and solid, and those holes in a sense are the monumental vacancies



108 109



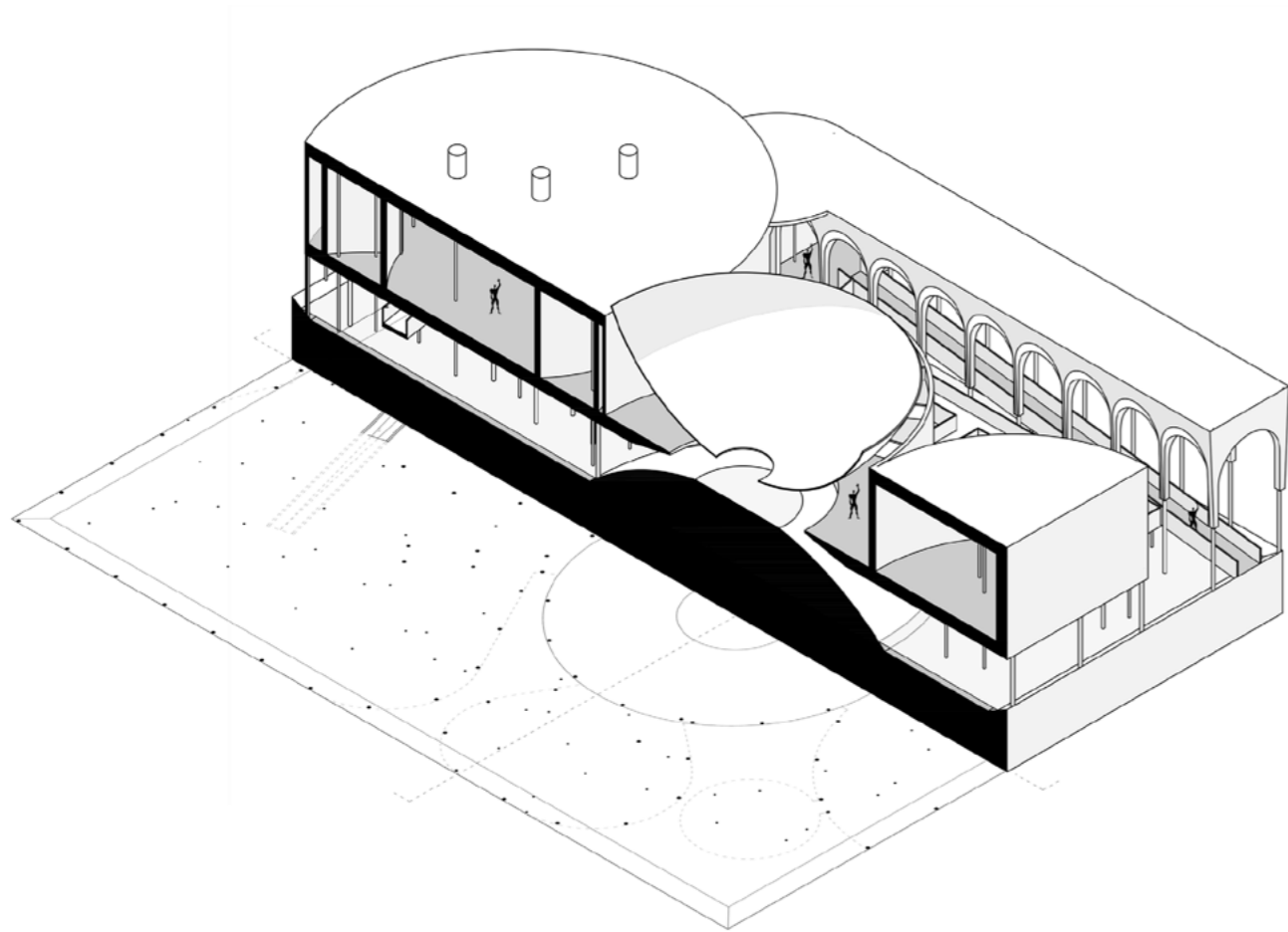

Axonometry

Gianfranco Sava / Yue Tam

110 111

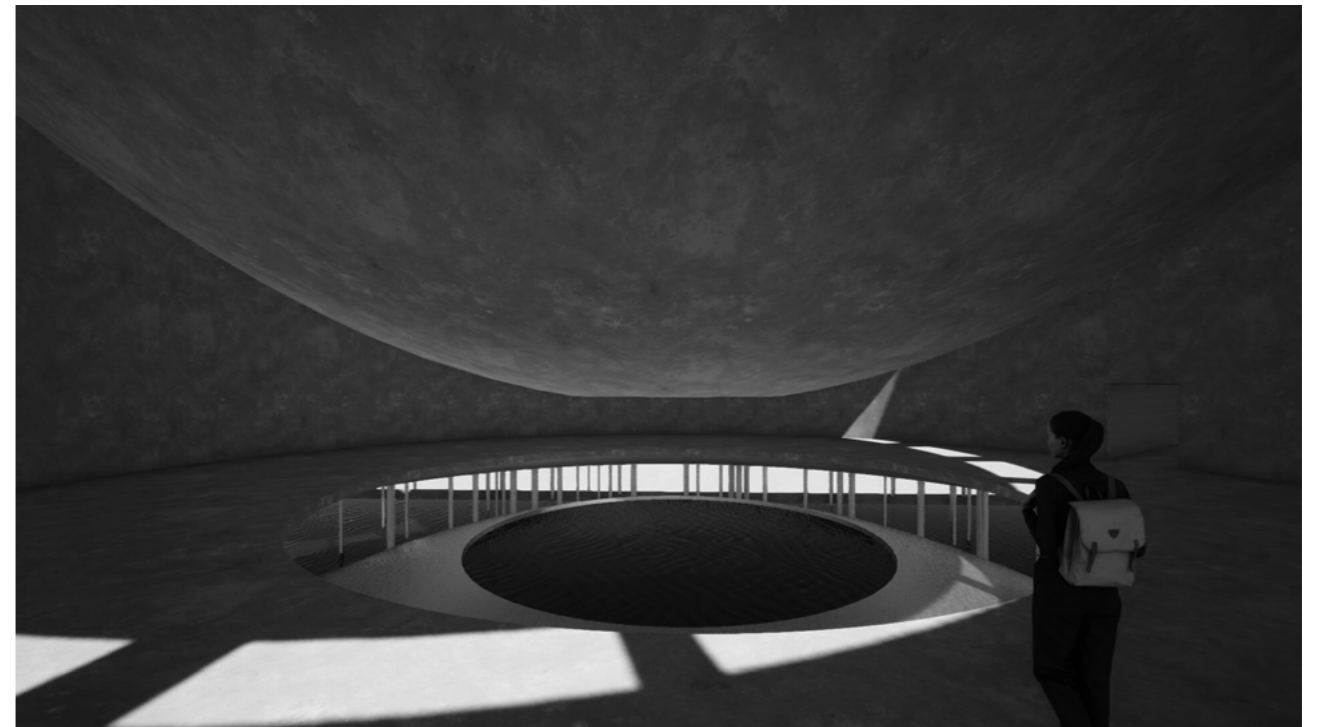

Atmosphere

Gianfranco Sava / Yue Tam

that define, without trying, the memory—traces of an abandoned set of futures. Such futures are found in grade B Utopian films, and then imitated by the suburbanite. The windows of City Motors auto sales proclaim the existence of Utopia through 1968 WIDE TRACK PONTIACS – Executive, Bonneville, Tempest, Grand Prix, Firebirds, GTO, Catalina, and LeMans – that visual incantation marked the end of the highway construction...

Has Passaic replaced Rome as The Eternal City? If certain cities of the world were placed end to end in a straight line according to size, starting with Rome, where would Passaic be in that impossible progression? Each city would be a three-dimensional mirror that would reflect the next city into existence. The limits of eternity seem to contain such nefarious ideas.

The last monument was a sand box or a model desert. Under the dead light of the Passaic afternoon the desert became a map of infinite disintegration and forgetfulness. This monument of minute particles blazed under a bleakly blowing sun, and suggested the sullen dissolution of entire continents, the drying up of oceans – no longer were there green forests and high mountains – all that existed were millions of grains of sand, a vast deposit of stones and bones pulverized into dust. Every grain of sand was a dead metaphor that equaled timelessness, and to decipher such metaphors would take one through the false mirror of eternity. This sandbox somehow doubled an open grave – a grave that children cheerfully play in...

all sense of reality was gone. In its place had come deep-seated illusions, absence of pupillary reaction to light, absence of knee reaction—symptoms all of progressive cerebral meningitis: the blanketing of the brain... Louis Sullivan, “one of the greatest architects,” quoted in Michel Butor’s *Mobile*.

... In the Greek temple the wall is as nothing; the entire interest is in the detached columns and the frieze they bear; in French Flamboyant, and in our detestable Perpendicular, the object is to get rid of the wall surface, and keep the eye altogether on tracery of line: in Romanesque work and Egyptian, the wall is a

112 113





114 115



confessed and honored member, and the light is often allowed to fall on large areas of it, variously decorated. Now, both these principles are admitted by Nature, the one in her woods and thickets, the other in her plains, and cliffs, and waters; but the latter is pre-eminently the principle of power, and, in some sense, of beauty also. For, **whatever infinity of fair form there may be in the maze of the forest, there is a fairer, as I think, in the surface of the quiet lake;** and I hardly know that association of shaft or tracery, for which I would exchange the warm sleep of sunshine on some smooth, broad, human-like front of marble.

Nevertheless, if breadth is to be beautiful, its substance must in some sort be beautiful; and we must not hastily condemn the exclusive resting of the northern architects in divided lines, until at least we have remembered the difference between a blank surface of Caen stone, and one mixed from Genoa and Carrara, of serpentine with snow: but as regards abstract power and awfulness, there is no question; without breadth of surface it is in vain to seek them, and it matters little, so that the surface be wide, bold, and unbroken, whether it be of brick or of jasper; the light of heaven upon it, and the weight of earth in it, are all we need: for it is singular how forgetful the mind may become both of material and workmanship, if only it have space enough over which to range, and to remind it, however feebly, of the joy that it has in contemplating the flatness and sweep of great plains and broad seas. And it is a noble thing for men to do this with their cut stone or moulded clay, and to make the face of a wall look infinite, and its edge against the sky like an horizon: or even if less than this be reached, it is still delightful to mark the play of passing light on its broad surface, and to see by how many artifices and gradations of tinting and shadow, time and storm will set their wild signatures upon it; and how in the rising or declining of the day the unbroken twilight rests long and luridly on its high lineless forehead, and fades away untraceably down its tiers of confused and countless stone...

... And among the first habits that a young architect should learn, is that of thinking in shadow, not looking at a design in its miserable liny

116 117



Francesco Zavoli / Paola Nicolacci

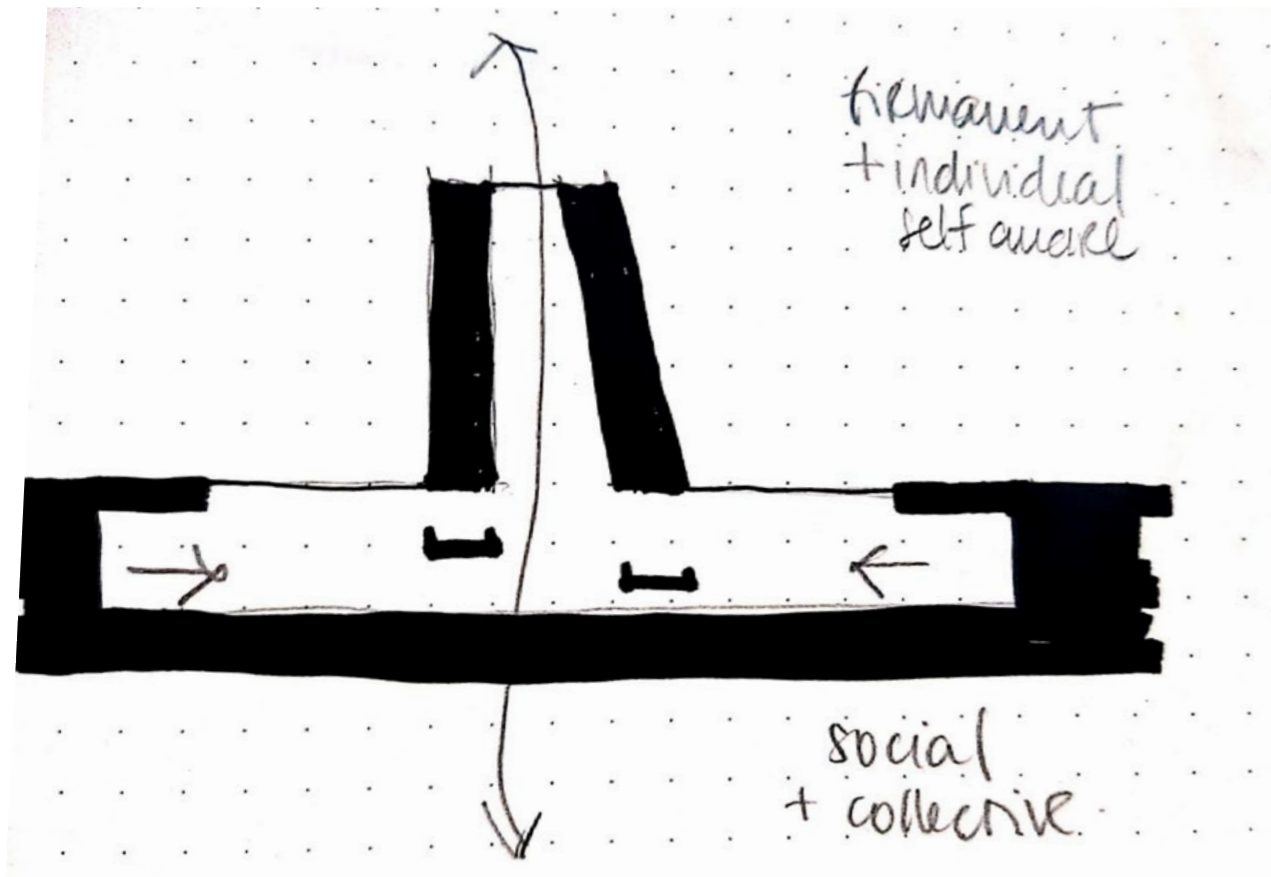

118 119

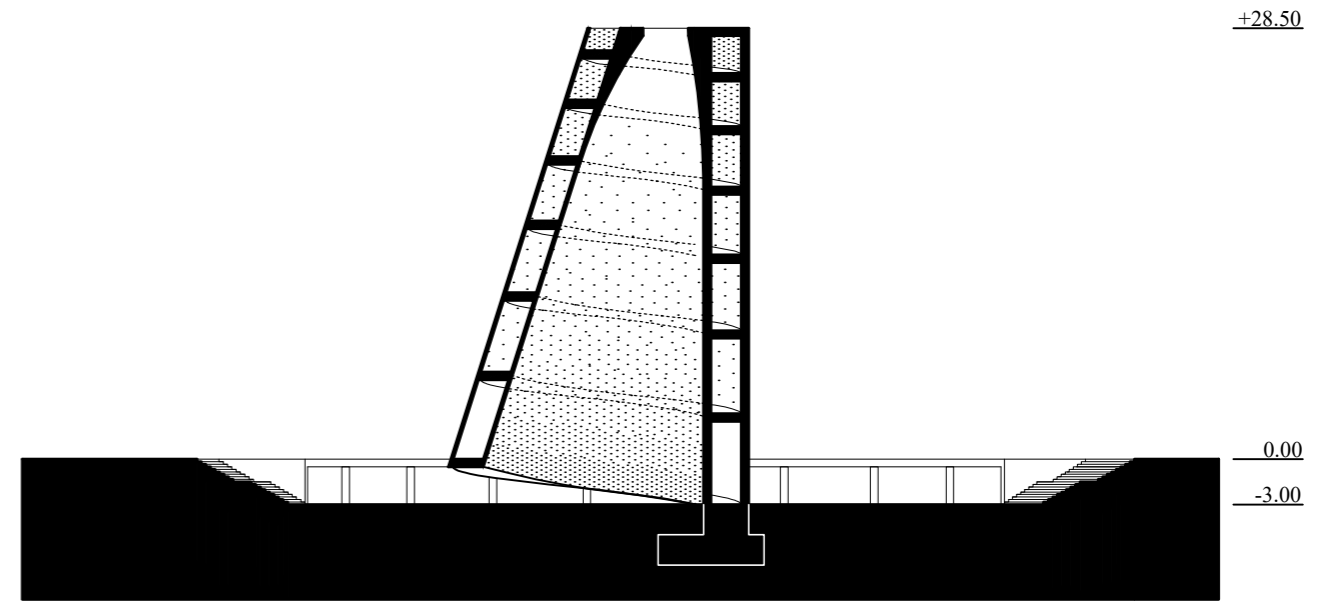

Section A-A

skeleton; but conceiving it as it will be when the dawn lights it, and the dusk leaves it; when its stones will be hot, and its crannies cool; when the lizards will bask on the one, and the birds build in the other. **Let him design with the sense of cold and heat upon him; let him cut out the shadows, as men dig wells in unwatered plains; and lead along the lights, as a founder does his hot metal; let him keep the full command of both, and see that he knows how they fall, and where they fade.** His paper lines and proportions are of no value: all that he has to do must be done by spaces of light and darkness; and his business is to see that the one is broad and bold enough not to be swallowed up by twilight, and the other deep enough not to be dried like a shallow pool by a noon-day sun...

I know not how we can blame our architects for their feebleness in more important work; their eyes are inured to narrowness and slightness: can we expect them at a word to conceive and deal with breadth and solidity? They ought not to live in our cities; there is that in their miserable walls which bricks up to death men's imaginations, as surely as ever perished forsworn nun. An architect should live as little in cities as a painter. **Send him to our hills, and let him study there what nature understands by a buttress, and what by a dome.** There was something in the old power of architecture, which it had from the recluse more than from the citizen. The buildings of which I have spoken with chief praise, rose, indeed, out of the war of the piazza, and above the fury of the populace: and Heaven forbid that for such cause we should ever have to lay a larger stone, or rivet a firmer bar, in our England! But we have other sources of power, in the imagery of our iron coasts and azure hills; of power more pure, nor less serene, than that of the hermit spirit which once lighted with white lines of cloisters the glades of the Alpine pine, and raised into ordered spires the wild rocks of the Norman sea; which gave to the temple gate the depth and darkness of Elijah's Horeb cave; and lifted, out of the populous city, grey cliffs of lonely stone, into the midst of sailing birds and silent air.

120 121

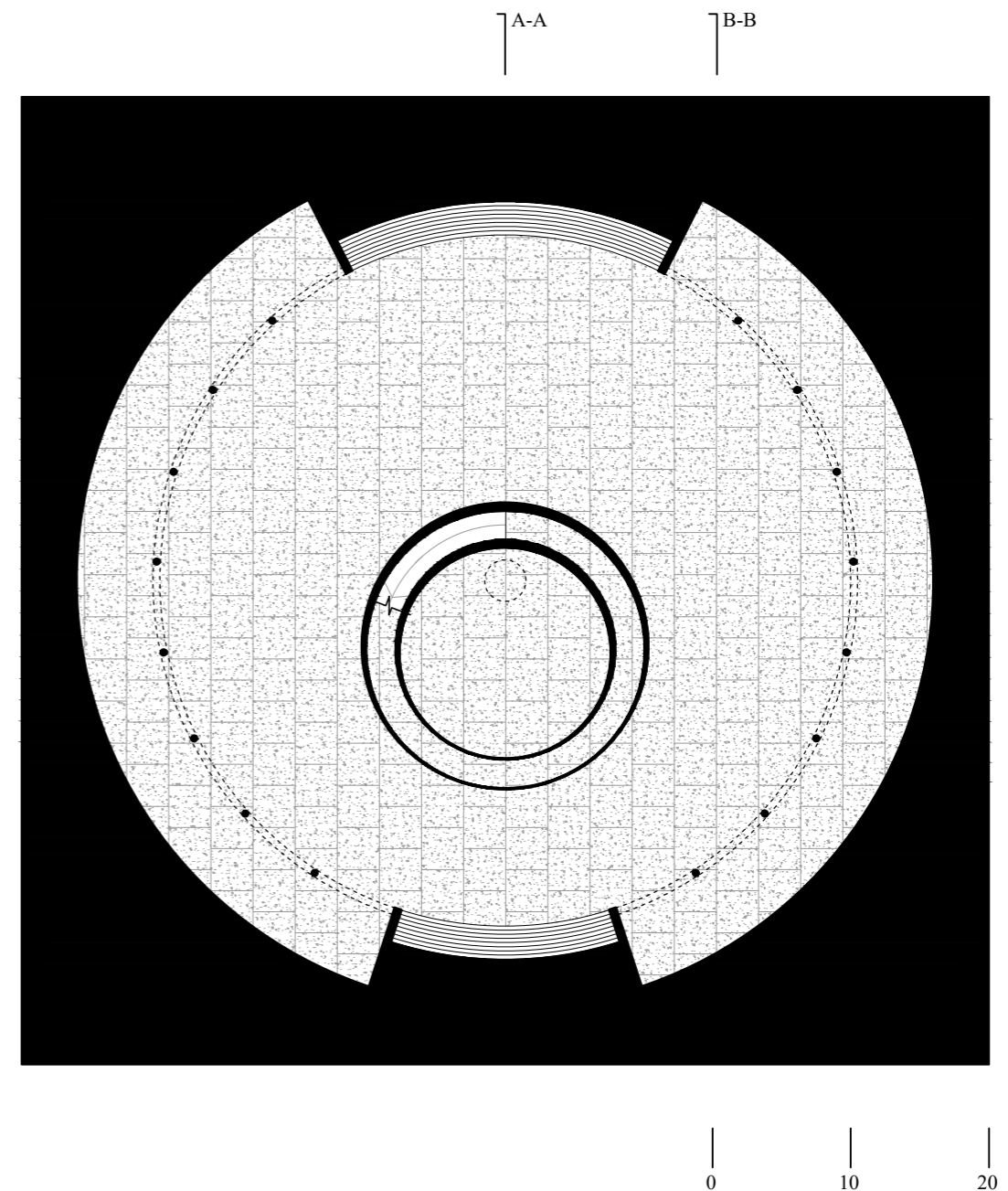



122 123



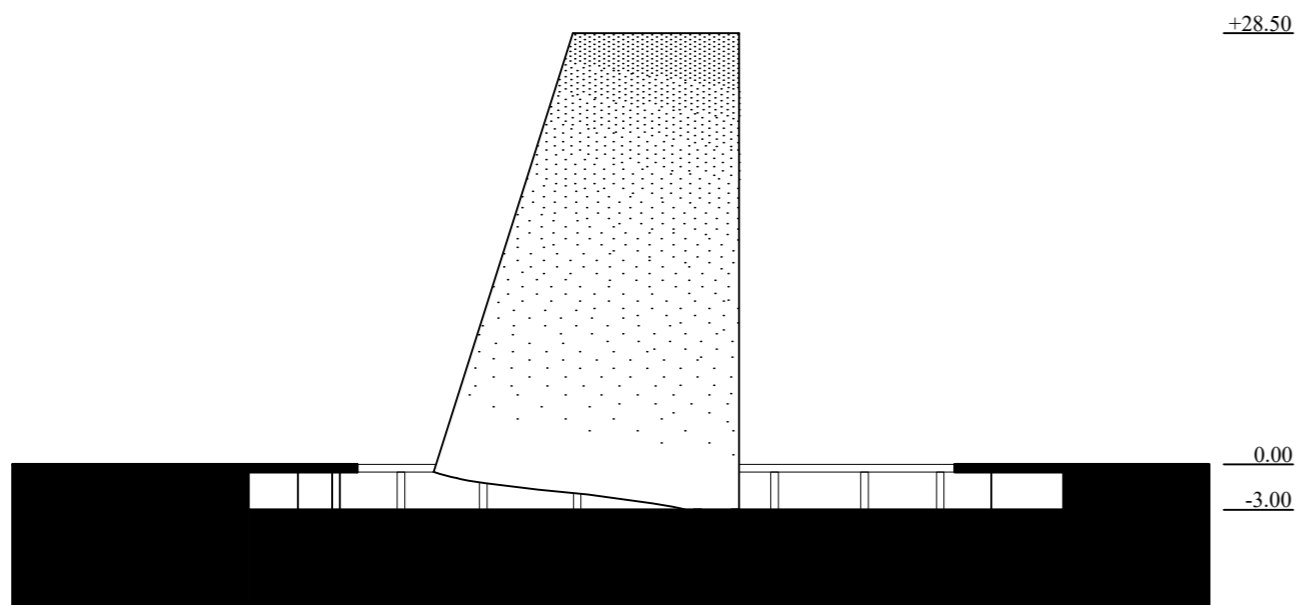

Section B-B

124 125

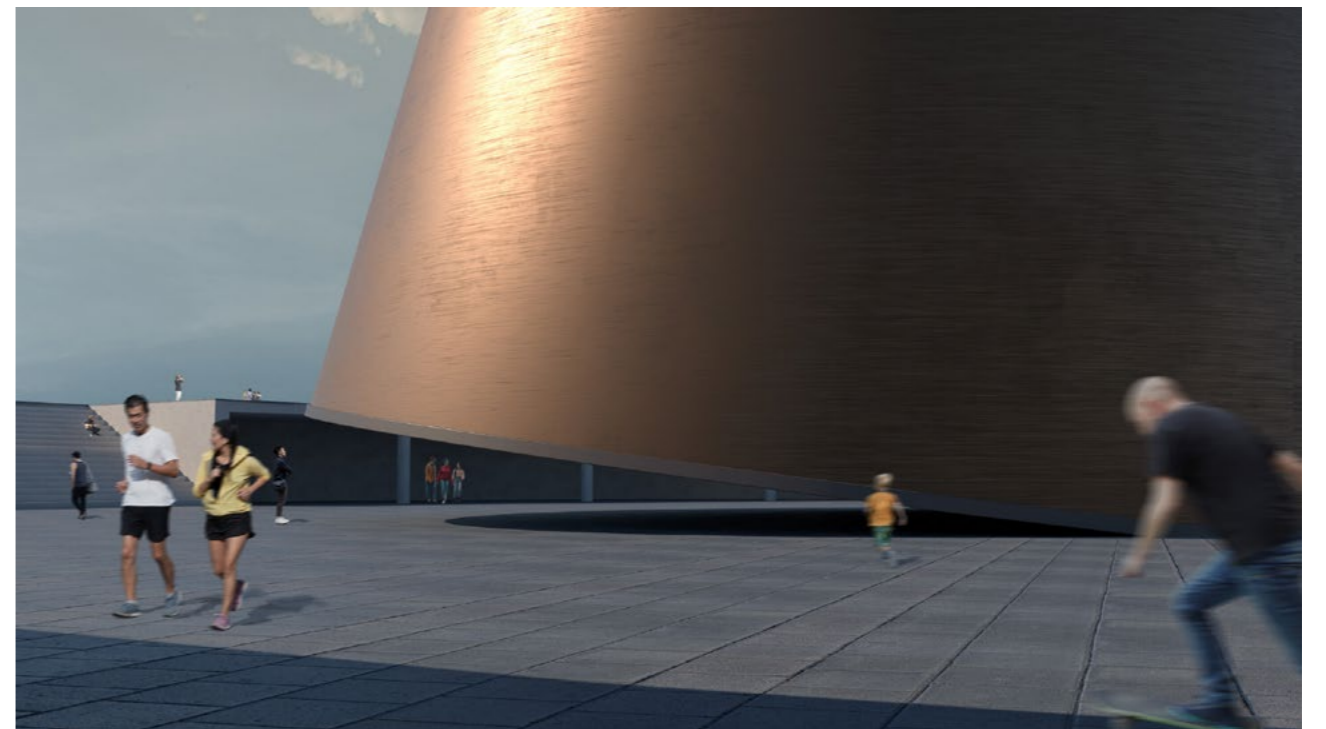

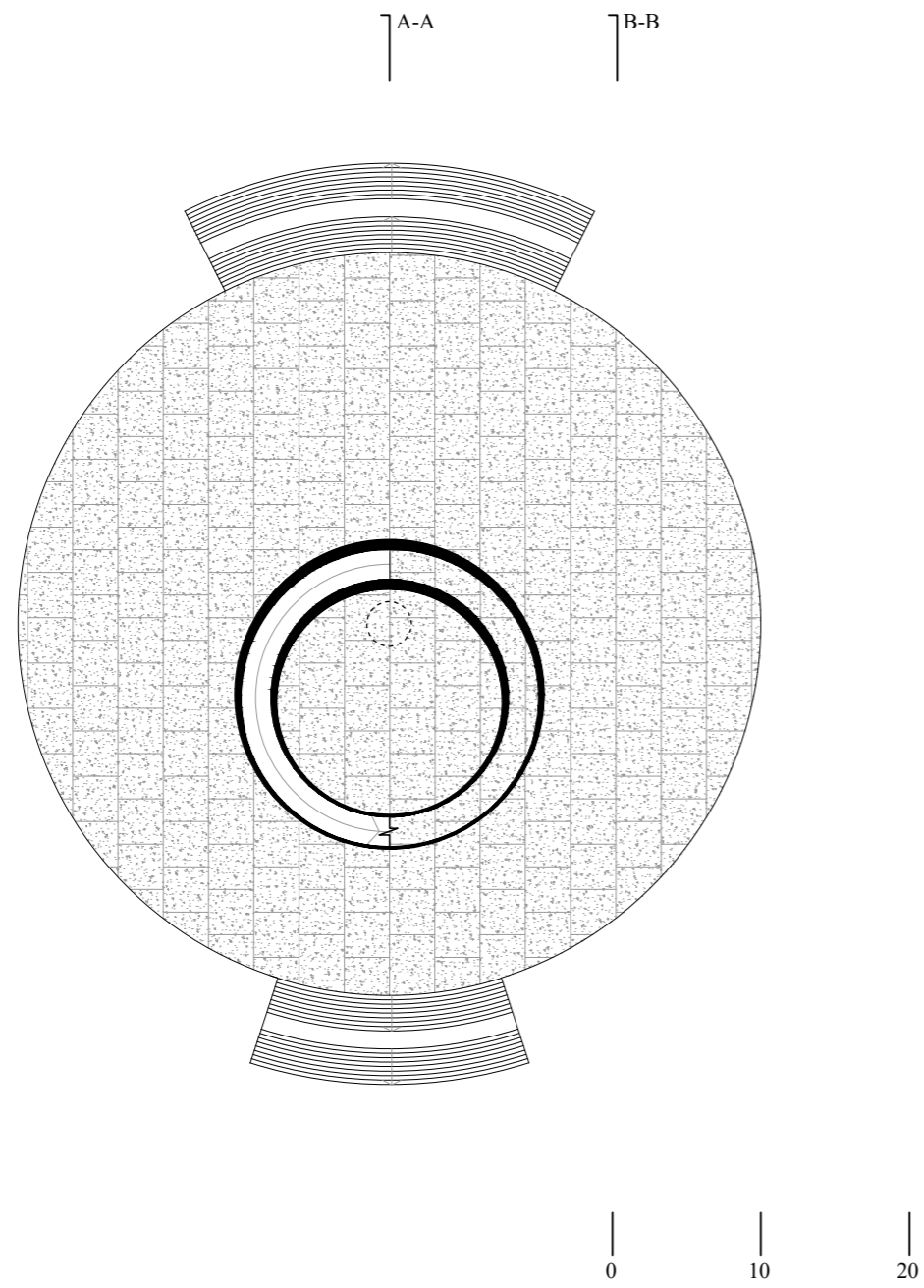

126 127

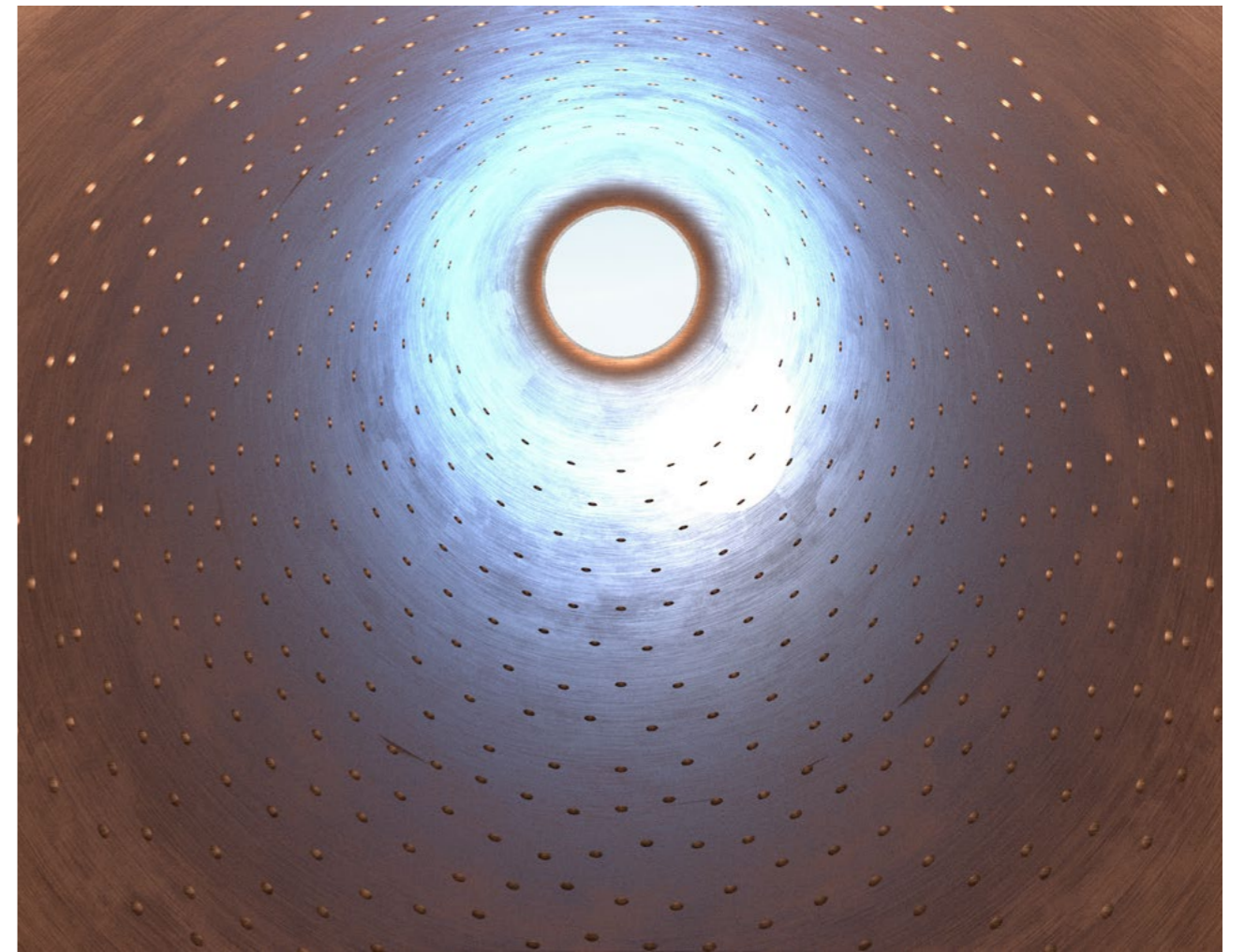

He stood naked at the edge of a cliff. The lake lay far below him. **A frozen explosion of granite burst in flight to the sky over motionless water.** The water seemed immovable, the stone flowing. The stone had the stillness of one brief moment in battle when thrust meets thrust and the currents are held in a pause more dynamic than motion. The stone glowed, wet with sunrays. The lake below was only a thin steel ring that cut the rocks in half. The rocks went on into the depth, unchanged. They began and ended in the sky. So that **the world seemed suspended in space, an island floating on nothing, anchored to the feet of the man on the cliff.**

His body leaned back against the sky. It was a body of long straight lines and angles, each curve broken into planes. He stood, rigid, his hands hanging at his sides, palms out. He felt his shoulder blades drawn tight together, the curve of his neck, and the weight of the blood in his hands. He felt the wind behind him, in the hollow of his spine. The wind waved his hair against the sky. His hair was neither blond nor red, but the exact color of ripe orange rind. He laughed at the thing which had happened to him that morning and at the things which now lay ahead. He knew that the days ahead would be difficult. There were questions to be faced and a plan of action to be prepared. He knew that he should think about it. He knew also that he would not think, because everything was clear to him already, because the plan had been set long ago, and because he wanted to laugh. He tried to consider it. But he forgot. He was looking at the granite.

He did not laugh as his eyes stopped in awareness of the earth around him. His face was like a law of nature--a thing one could not question, alter or implore. It had high cheekbones over gaunt, hollow cheeks; gray eyes, cold and steady; a contemptuous mouth, shut tight, the mouth of an executioner or a saint. He looked at the granite. To be cut, he thought, and made into walls. He looked at a tree. To be split and made into rafters. He looked at a streak of rust on the stone and thought of iron ore under the ground. To be melted and to emerge as girders against the sky. These rocks, he thought, are here for me; waiting for the drill, the dynamite and my voice; waiting to be split, ripped, pounded, reborn; waiting for the shape my hands

128 129

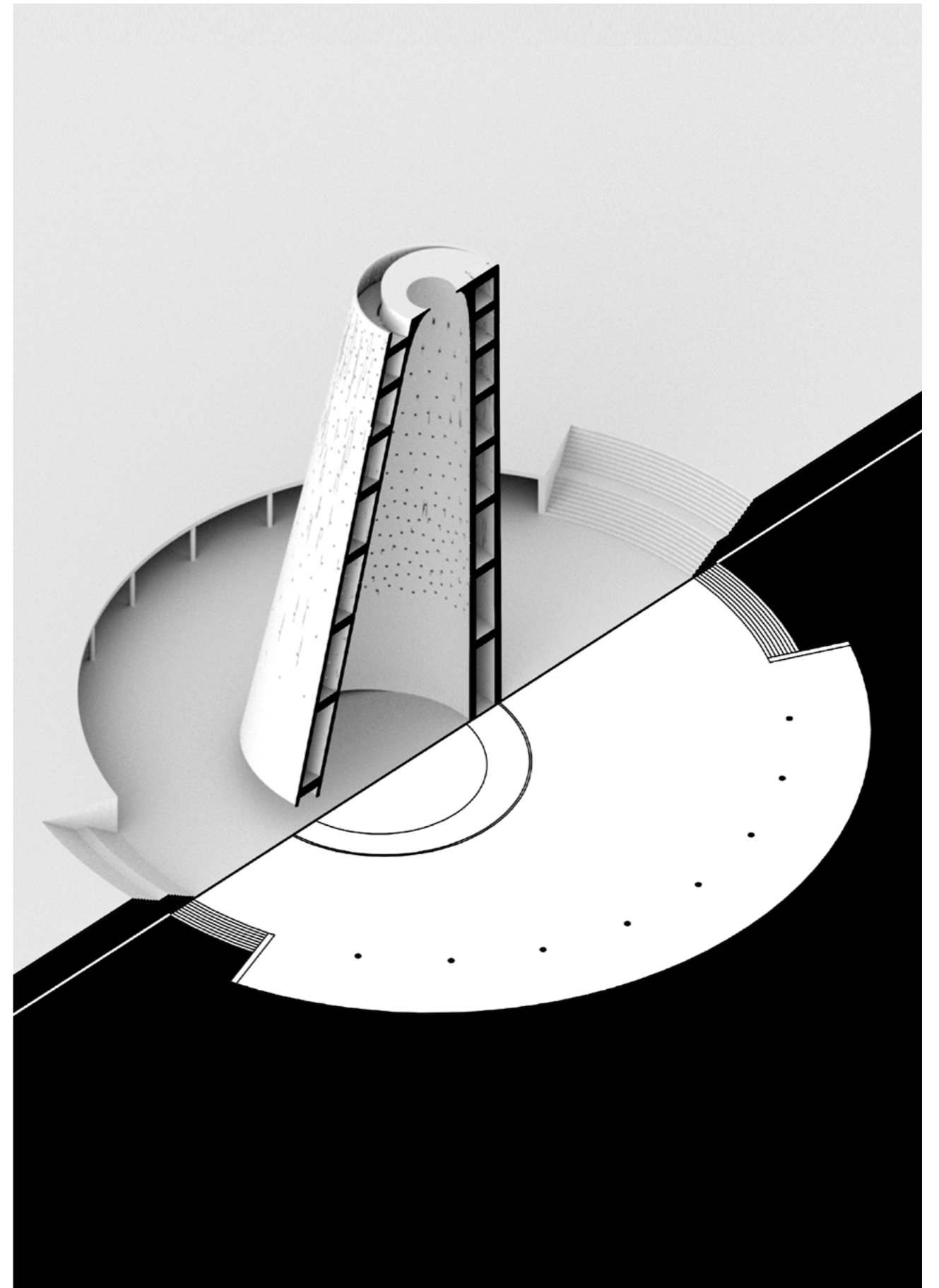



Francesco Zavoli / Paola Nicolacci

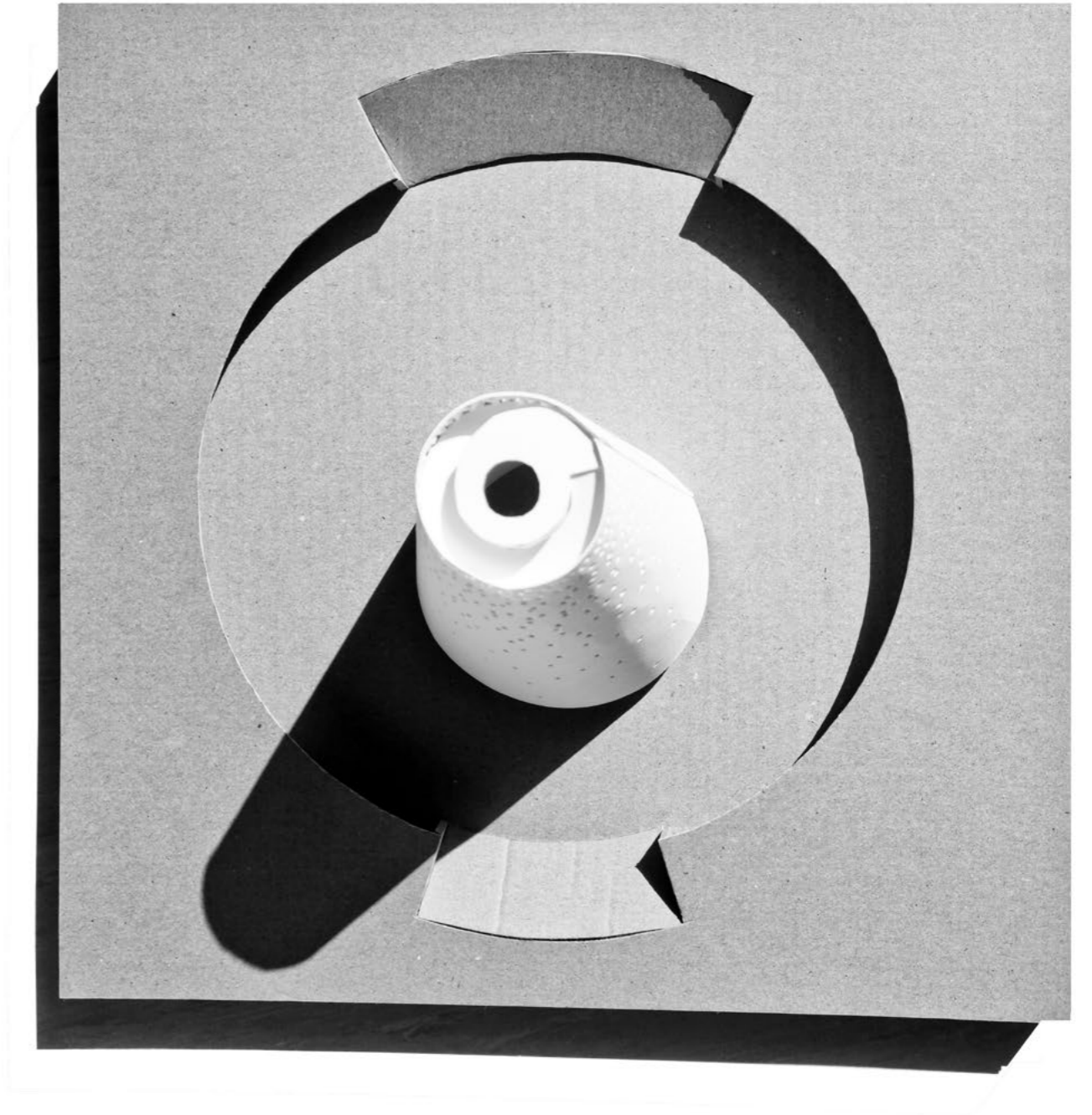

Francesco Zavoli / Paola Nicolacci



132 133

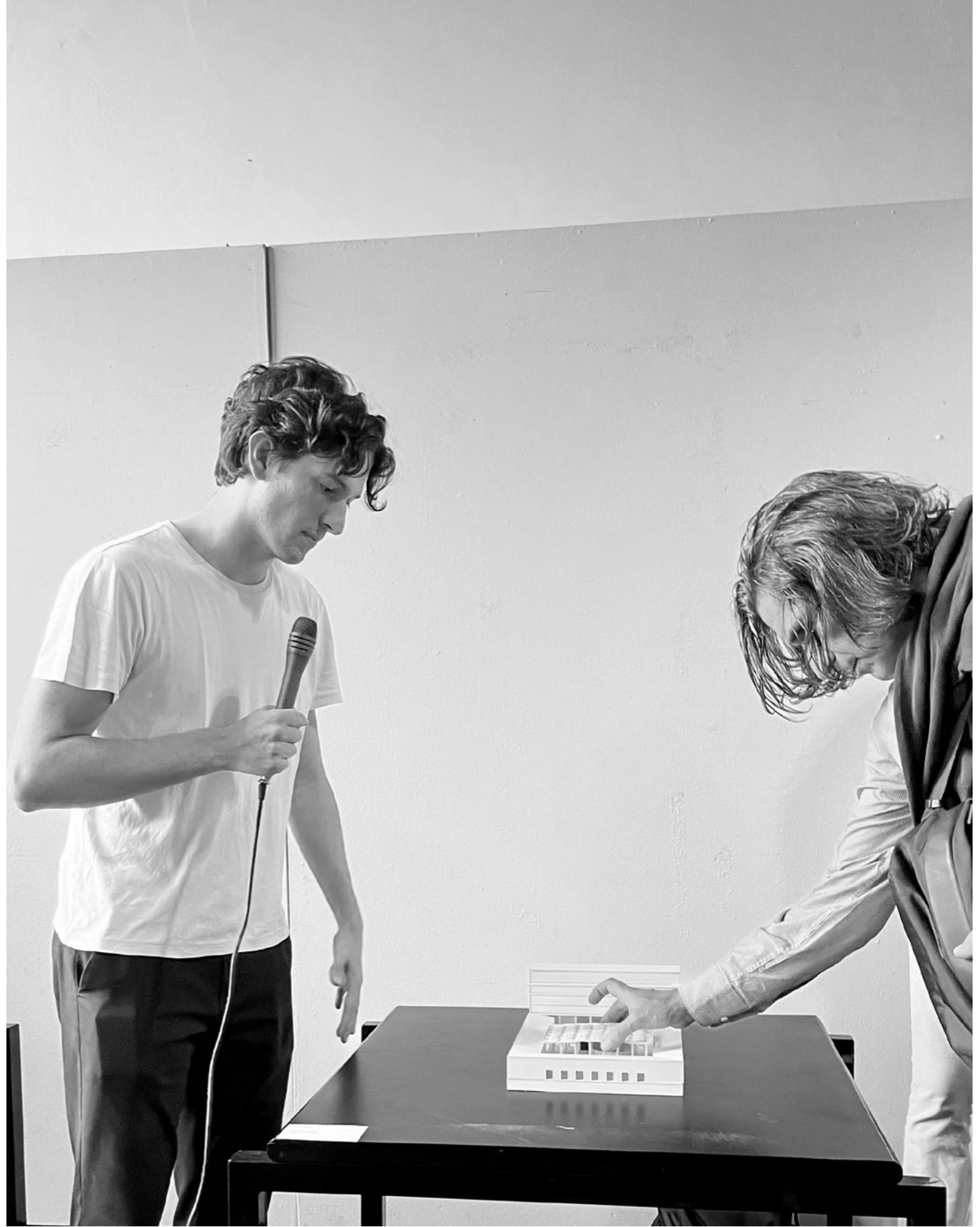

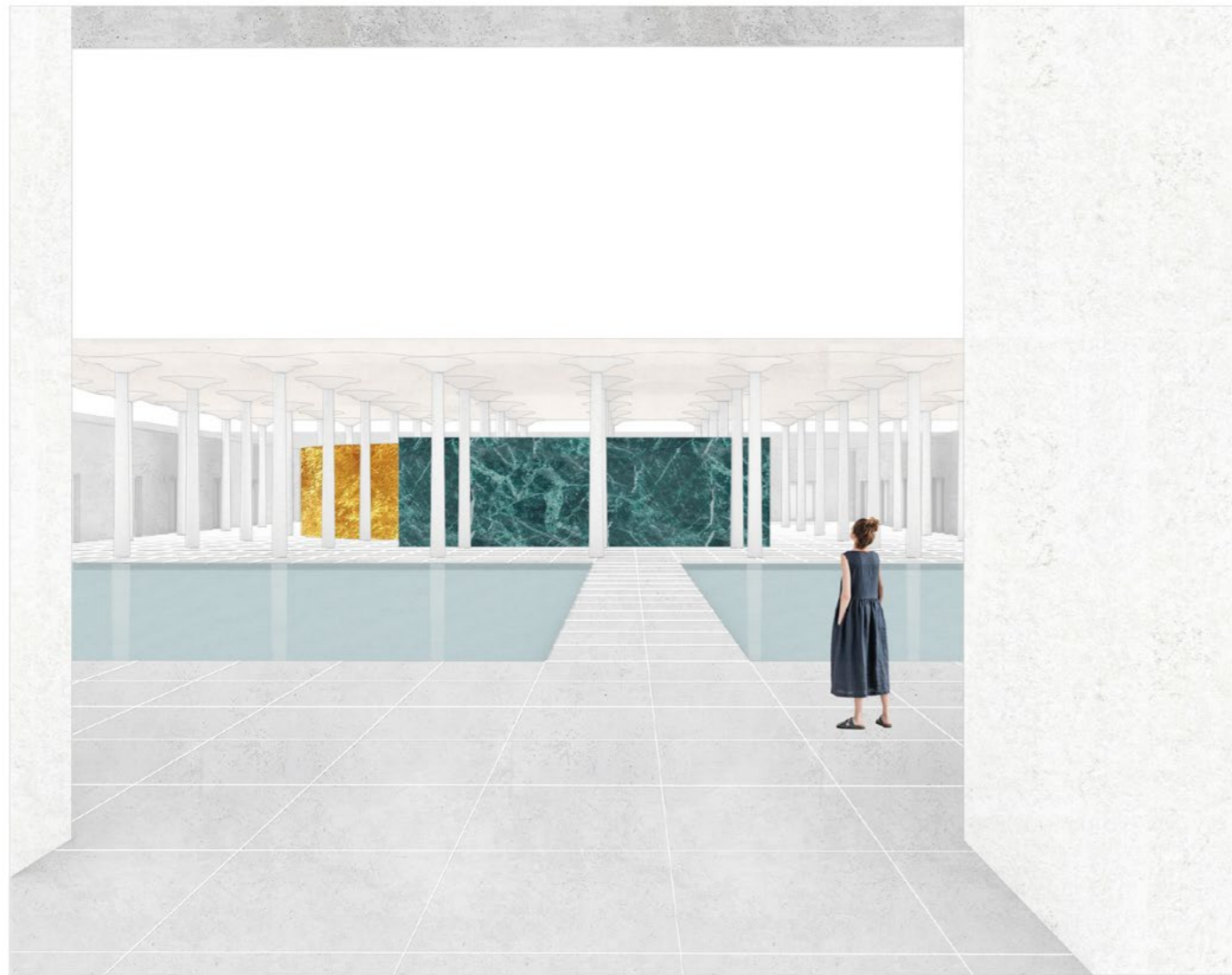

134 135

will give them. Then he shook his head, because he remembered that morning and that there were 7 many things to be done. He stepped to the edge, raised his arms, and dived down into the sky below...

... She rose above the broad panes of shop windows. The channels of streets grew deeper, sinking. She rose above the marquees of movie theaters, black mats held by spirals of color. Office windows streamed past her, long belts of glass running down. The squat hulks of warehouses vanished, sinking with the treasures they guarded. Hotel towers slanted, like the spokes of an opening fan, and folded over. The fuming matchsticks were factory stacks and the moving gray squares were cars. The sun made lighthouses of peaked summits, they reeled, flashing long white rays over the city. The city spread out, marching in angular rows to the rivers. It stood held between two thin black arms of water. It leaped across and rolled away to a haze of plains and sky.

Flat roofs descended like pedals pressing the buildings down, out of the way of her flight. She went past the cubes of glass that held dining rooms, bedrooms and nurseries. She saw roof gardens float down like handkerchiefs spread on the wind. Skyscrapers raced her and were left behind. The planks under her feet shot past the antennae of radio stations.

The hoist swung like a pendulum above the city. It sped against the side of the building. It had passed the line where the masonry ended behind her. There was nothing behind her now but steel ligaments and space. She felt the height pressing against her eardrums. The sun filled her eyes. The air beat against her raised chin. She saw him standing above her, on the top platform of the Wynand Building.

He waved to her. **The line of the ocean cut the sky.**

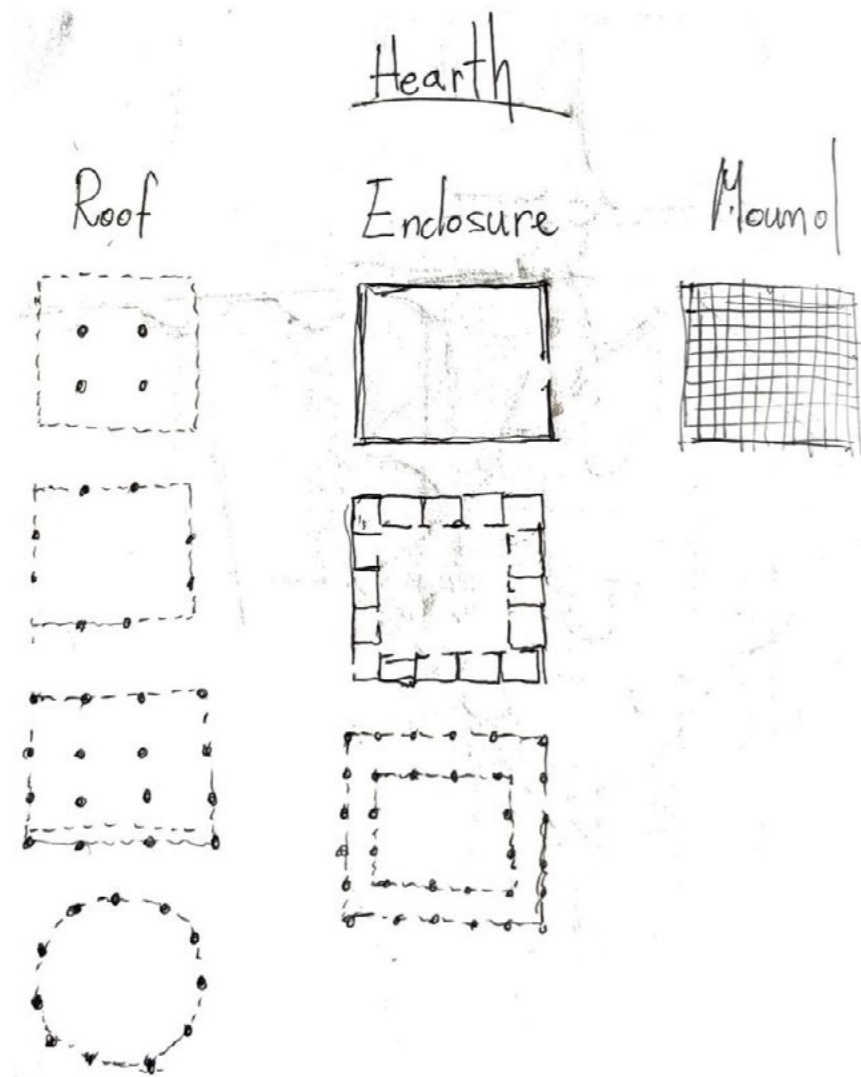

136 137

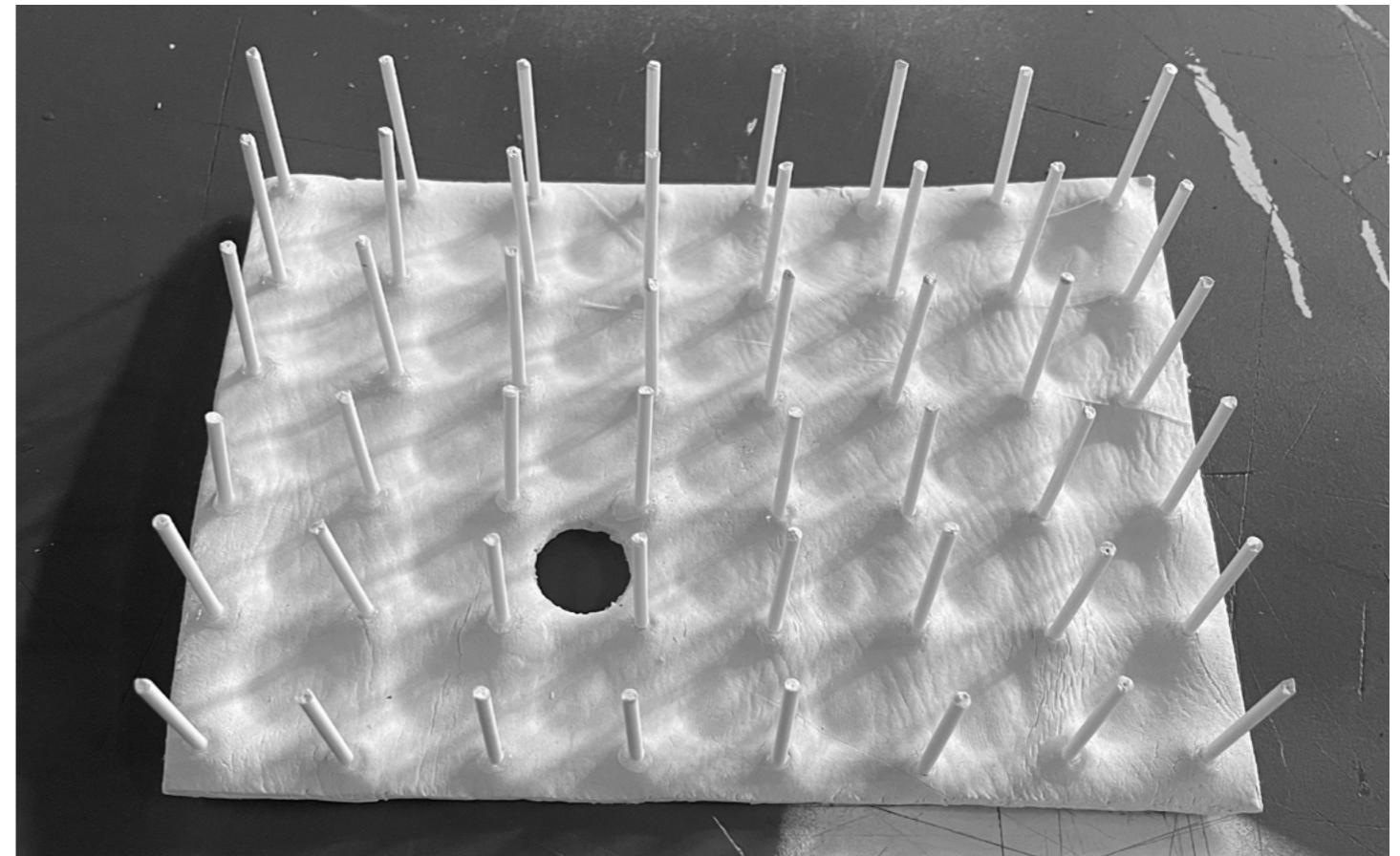

“The hearth [...] It is the first and most important, the moral element of architecture. Around it were grouped the three other elements: **the roof, the enclosure and the mound**, the protecting negations or defenders of the hearth’s flame against the three hostile elements of nature.”

Gottfried Semper

“Orderly metamorphosis can occur, first of all, through the evolution of a **type-form**...Each type-form can beget **complicated species**.”

Richard Sennet



138 139

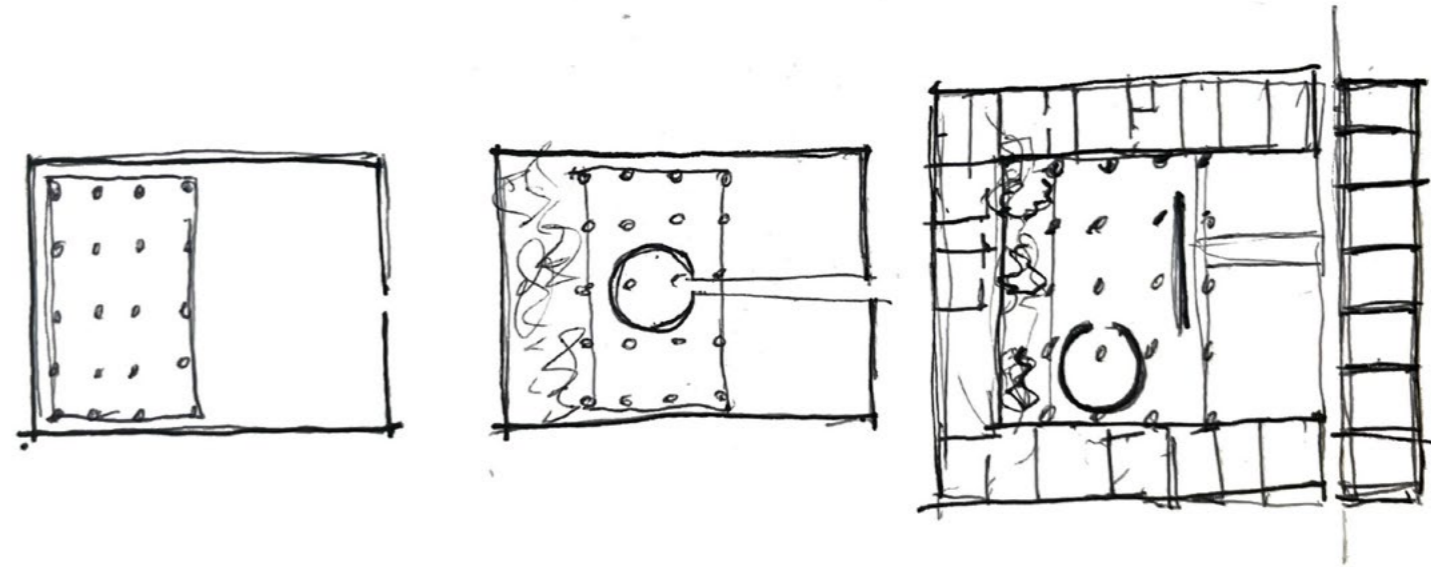

“Yes, nothing is transmissible except **thought**, the noble fruit of our labor. This thought may or may not triumph over fate in the hereafter, and perhaps it will assume a **different, unforeseeable dimension.**”

Le Corbusier

“When I see a plan before me, I see it for the **character of the spaces**, and their **relations**. I see it as the structure of the spaces in their light.”

Louis Kahn

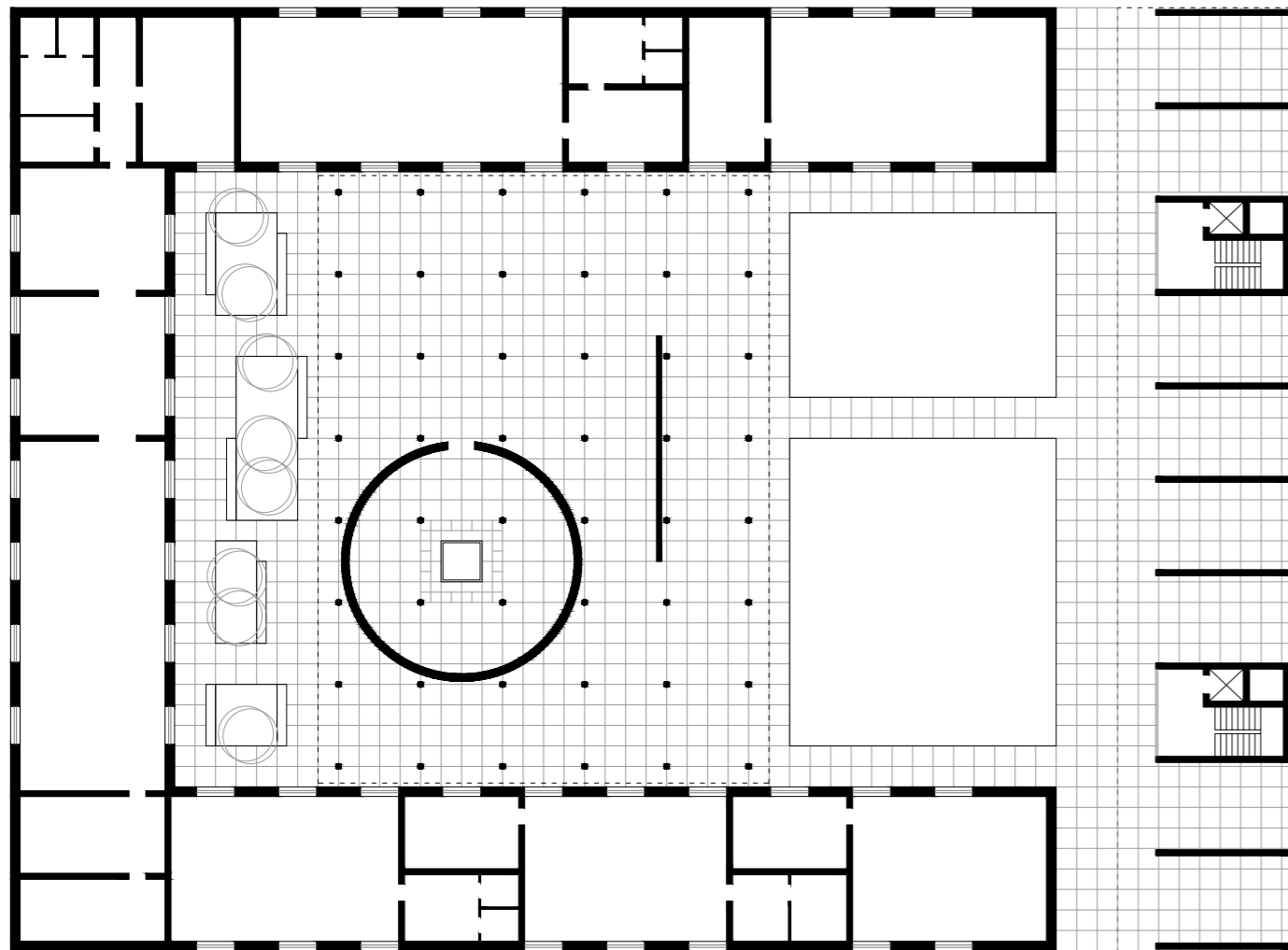

140 141





142 143



The ocean mounted as the city descended. She passed the pinnacles of bank buildings. She passed the crowns of the courthouses. She rose above the spires of churches.

Then there was only the ocean, the sky and the figure of Howard Roark.

I accompanied him all over the house, going from room to room, from the library to the cellar, and when he returned to the vast hall with its great windows, which look out to the most beautiful scenery in the world, I offered him a glass of Vesuvian wine from the vineyards of Pompeii. "Prosit!" he said, raising his glass, and he drained it at a single draught. Then, before leaving, he asked me whether I had bought my house as it stood or whether I had designed and built it myself. I replied -and it was not true- that I had bought the house as it stood. And with a sweeping gesture, indicating the sheer cliff of Matromania, the three gigantic rocks of the Faraglioni, the peninsula of Sorrento, the islands of the Sirens, the far-away blue coastline of Amalfi, and the golden sands of Paestum, shimmering in the distance, **I said to him: "I designed the scenery."**

Au détour du chemin, Paul et Lang aperçoivent la villa de Jérémie Prokosch, une sorte de bunker rouge qui domine orgueilleusement la mer.

"THE IRREFUTABLE LINE / THE IRREVOCABLE GRAPH"

I can therefore sketch this figure: **A vertical line.** To the left of this vertical line, a black area, a descending arrow, the trajectory of a catastrophe, of atomic war (everything will be destroyed, including the newly rich of this adventure).

To the right of the vertical line an arrow soars upward toward the light bearing the fate of "The Three Human Establishments." ...

144 145

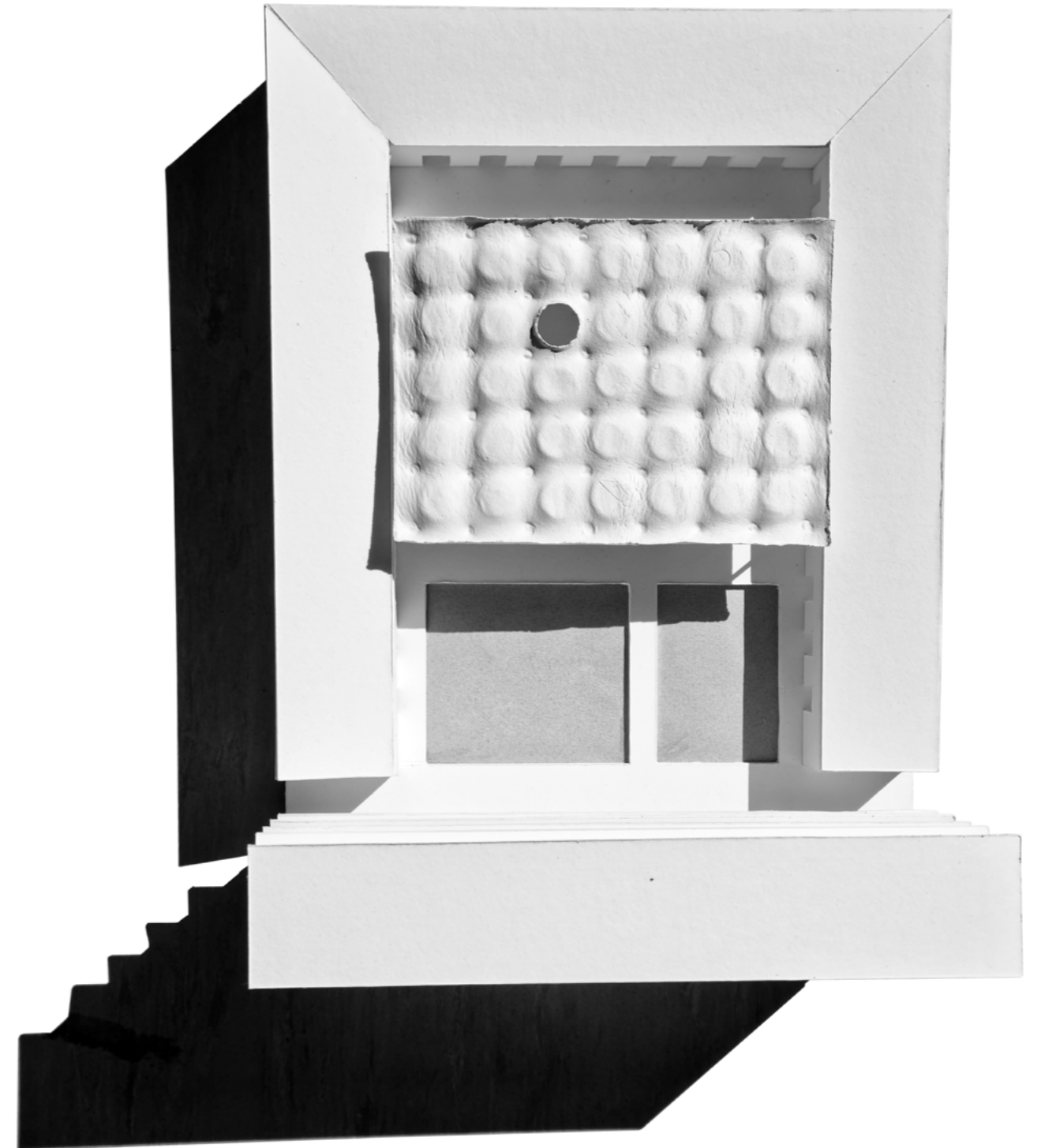

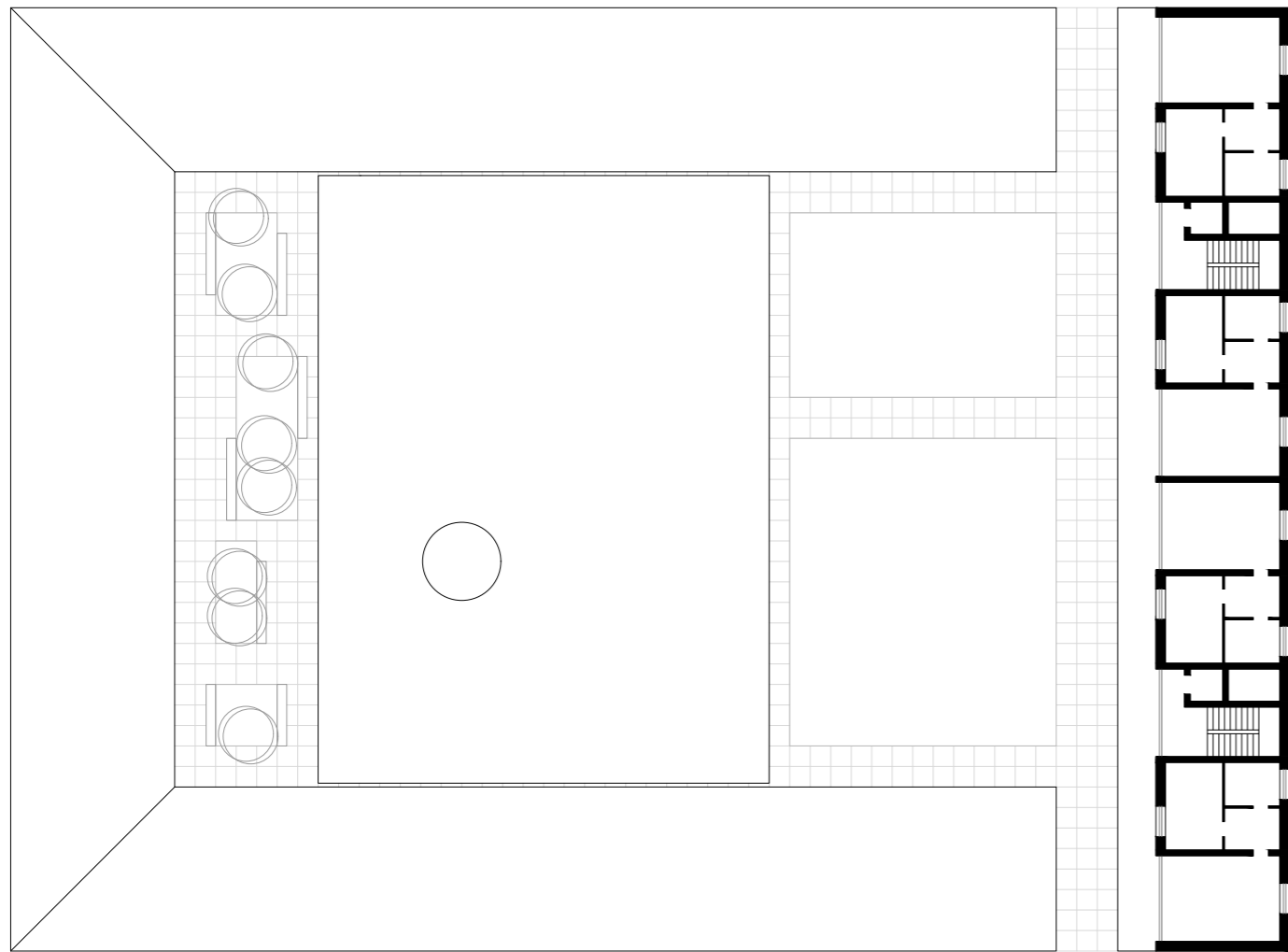

146 147

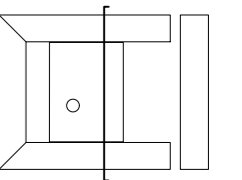
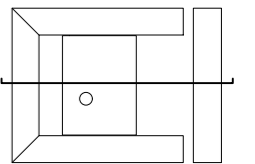
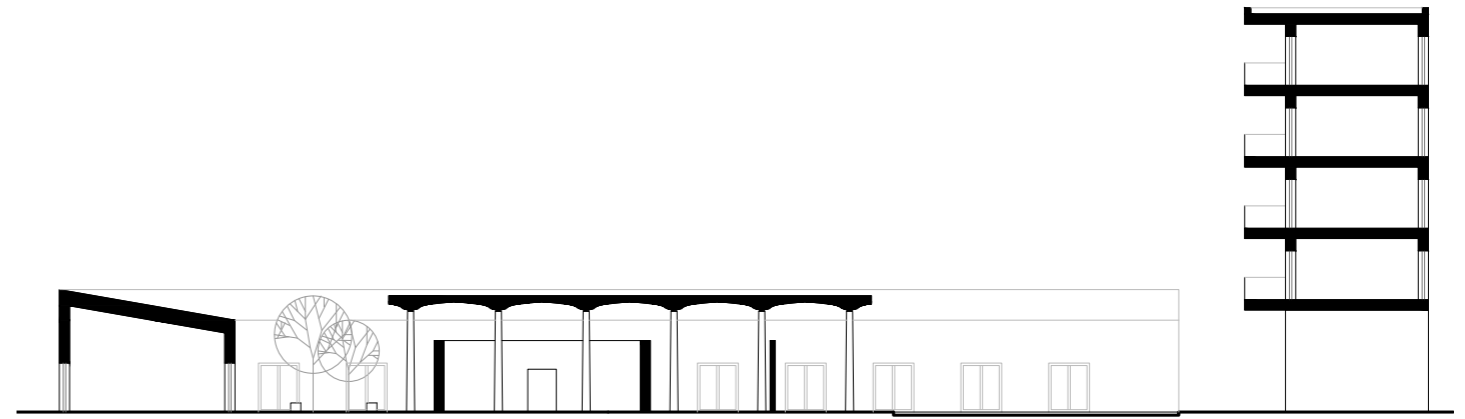

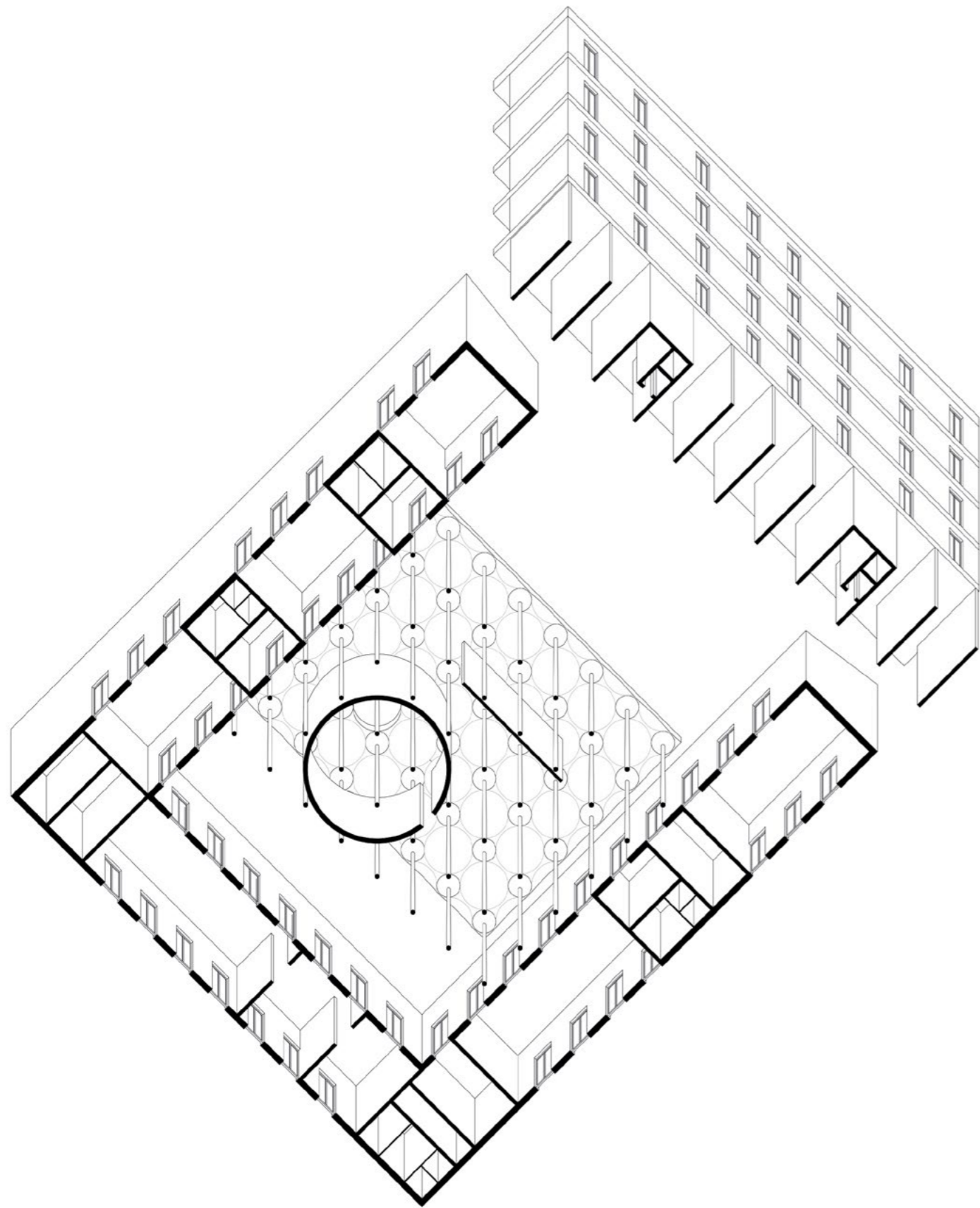

Recently I had to proofread the manuscript for a book written in 1911: *Le Voyage d'Orient*. Tobito, a veteran from the atelier at 35 rue de Sèvres, had come to pay a visit from Venezuela to my apartment at rue Nungesser. Jean Petit then arrived with the text of *Le Voyage d'Orient*. Together we drank pastis and spoke at length. I remember telling both of them that the line of conduct of little Charles-Edouard Jeanneret at the time of *Le Voyage d'Orient* was the same as that of *père* Corbu. Everything is a question of perseverance, of work, of courage. There are no glorious signs in heaven. But courage is an inner force, which alone can justify or not justify existence. I was happy to see Tobito again, to see that he had persevered, that he was among the faithful. When the three of us parted, I said to Tobito, who was planning on coming back to see me the following year: "Yes, in Paris or on another planet..." and I said to myself: "So, from lime lo time they will probably have a good thought for *père* Corbu."

Finding myself alone again, I thought of that wonderful phrase from the Apocalypse: "**There was silence in heaven for about half an hour.**" Yes, nothing is transmissible except thought, the noble fruit of our labor. This thought may or may not triumph over fate in the hereafter, and perhaps it will assume a different, unforeseeable dimension. Politicians, to be sure, leave no stone unturned and make the best of weaknesses in order to enlist support: they are bent on reassuring the weak and the doubting, the frightened. But life can be revived through plans —the potential life that lies in wail in the pastures and among the flocks, in these abandoned lands, in these sprawling cities that have to be pulled down, in the workplaces, and in the factories that must be made as beautiful as joy...outside the force of habit and jaded civil servants.

We must rediscover **man**. We must rediscover **the straight line** that joins the axis of **fundamental laws**: biology, nature, the cosmos. A straight line unbending like the horizon of the sea. The **professional man**, also, unbending like the horizon of the sea, ought to be a measuring instrument able to serve as a builder's level, as a datum line in the midst of flux and mobility. That is his social role. This role demands that he be clear-



150 151





sighted. His followers have set up a perpendicular line in his mind. The moral: not to give a damn for honors but to rely on oneself, to act in accordance with one's own conscience. It is not by playing the hero that one is able to act, able to undertake tasks and to realize them. All this happens inside the head, formulating itself, passing through an embryonic stage, little by little in the course of a lifetime that flies by in a vertigo, whose end one reaches without even realizing it.

The platform as an architectural element is a fascinating feature. I first fell in love with it in Mexico on a study trip in 1949, where I found many variations, both in size and idea of, the platform, and where many of the platforms are alone without anything but the surrounding nature. All the platforms in Mexico were positioned and formed with great sensitivity to the natural surroundings and always with a deep idea behind. A great strength radiates from them. The feeling under your feet is the same as the firmness you experience when standing on a large rock.

Let me give you two examples of the brilliance of the idea behind. In Yucatan, in Uxmal and Chichen-Itza, the same principle is followed, based on identical natural surroundings. Yucatan is a flat lowland covered with an inaccessible jungle, which grows to a certain uniform defined height. In this jungle the Mayans lived in their villages with small pieces of land cleared for cultivation, and their surrounding, background as well as roof, was the hot, damp, green jungle. No large views, no up and down movements. **By introducing the platform with its level at the same height as the jungle top, these people had suddenly obtained a new dimension of life**, worthy of their devotion to their Gods. On these high platforms – many of them as long as 100 metres – they built their temples. They had from here the sky, the clouds and the breeze, and suddenly the jungle roof had been converted into a great open plain. By this architectural trick they had completely changed the landscape and supplied their visual life with a greatness corresponding to the greatness of their Gods.

Today you can still experience this wonderful variation in feeling from the closeness in the jungle to the vast openness on the platform top. It is parallel to

154

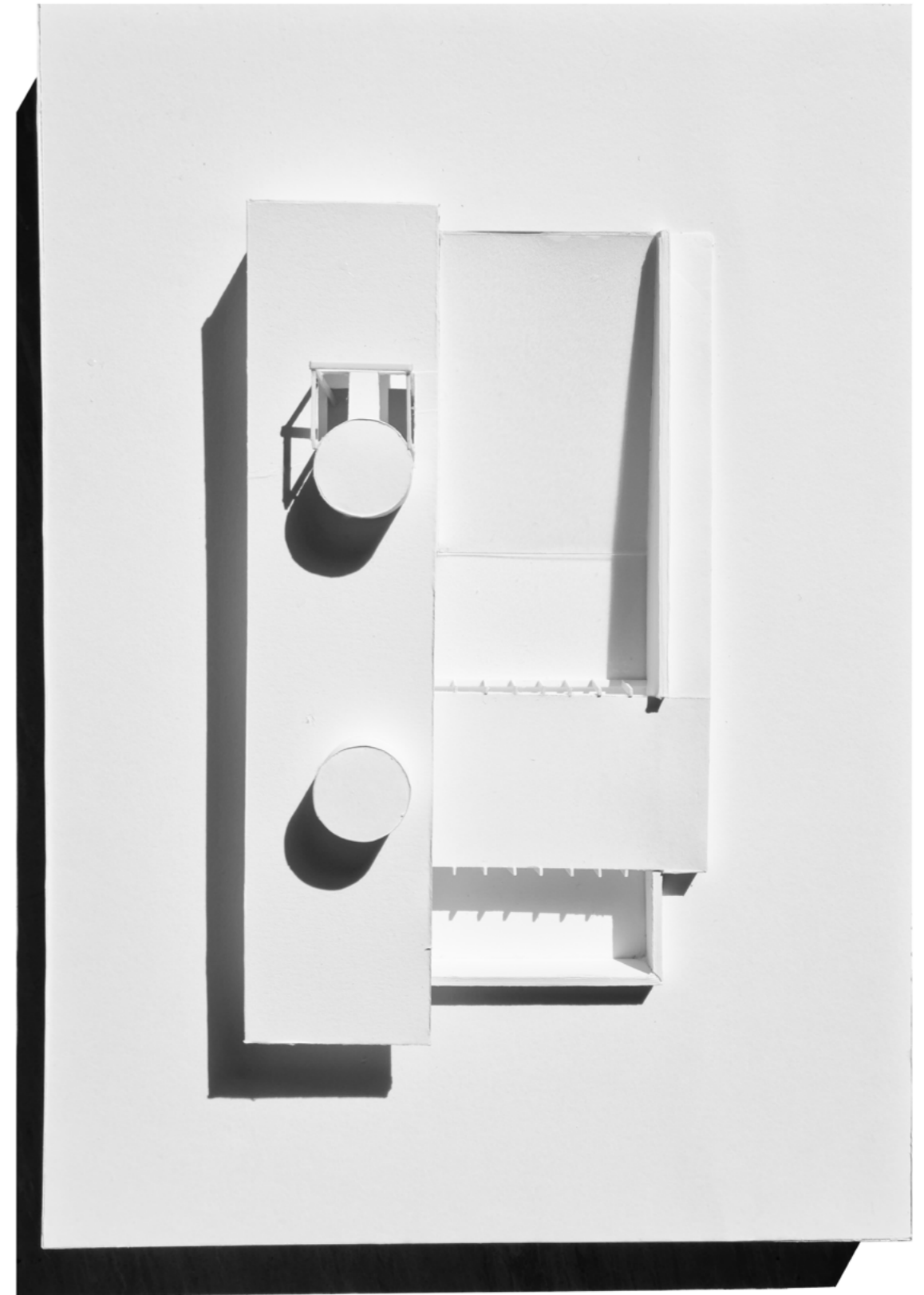



156 157



atmosphere

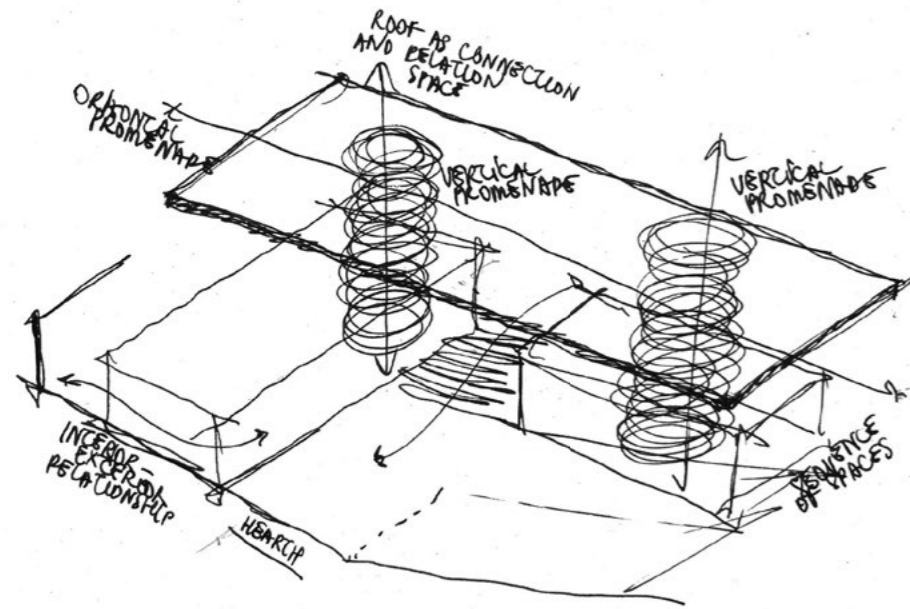

158 159

“ Architecture is internal circulation and not for exclusive functional reasons (...), but in particular for reasons of emotion, for the different aspects of the work; (...) Good architecture is “walked” and “traversed” inside as well as outside. ”

Corbusier, L. (1957). *Entretien: avec les étudiants des écoles d'architecture*

The project is constituted and explored through a sequence of spaces, lights and shadows. There are also various relationships with the context through a fence that breaks and opens and an overhanging roof that protects the space. Monumental circular stairwells constitute the vertical circulation and make the route legible.

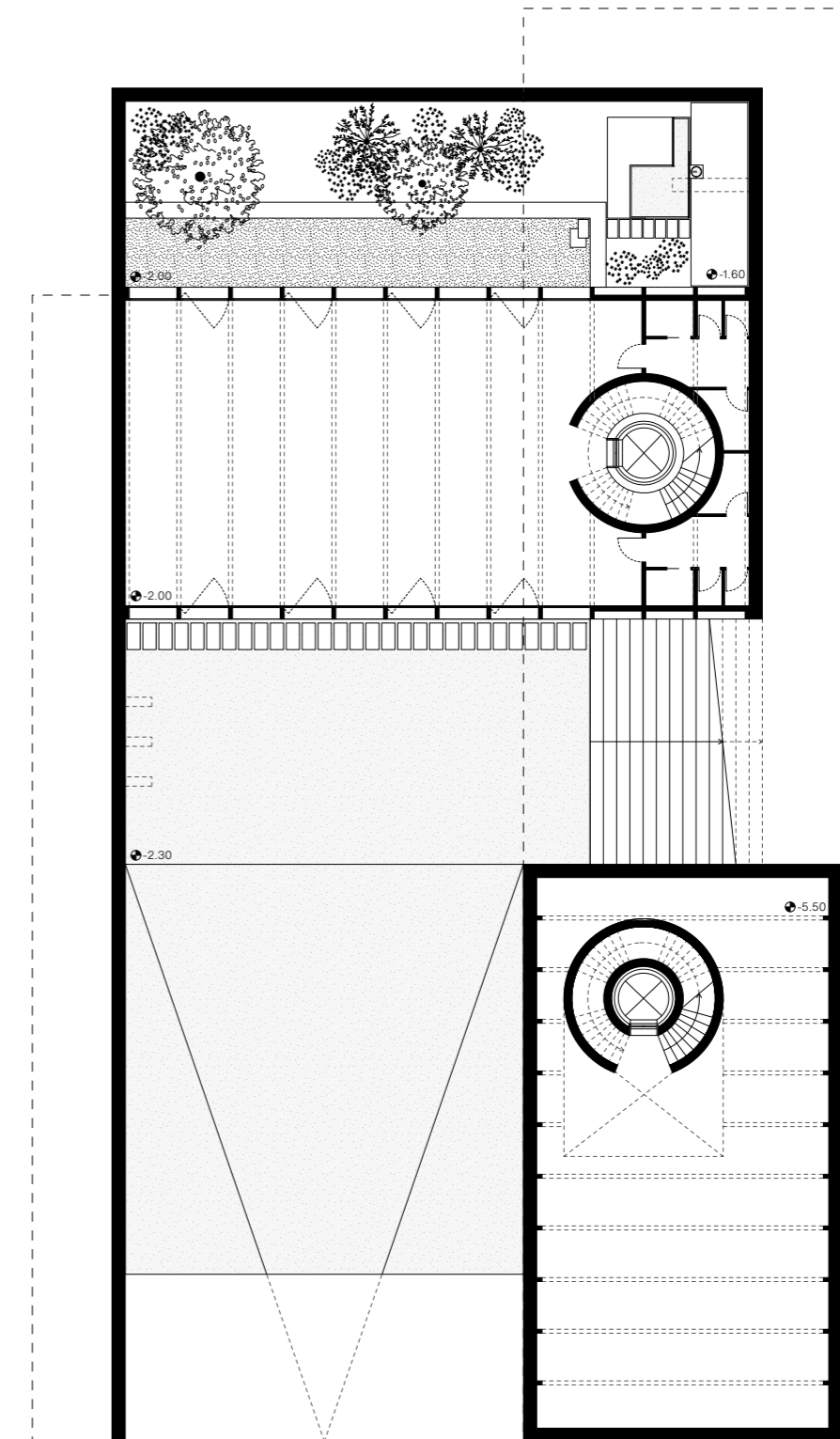

basement plan



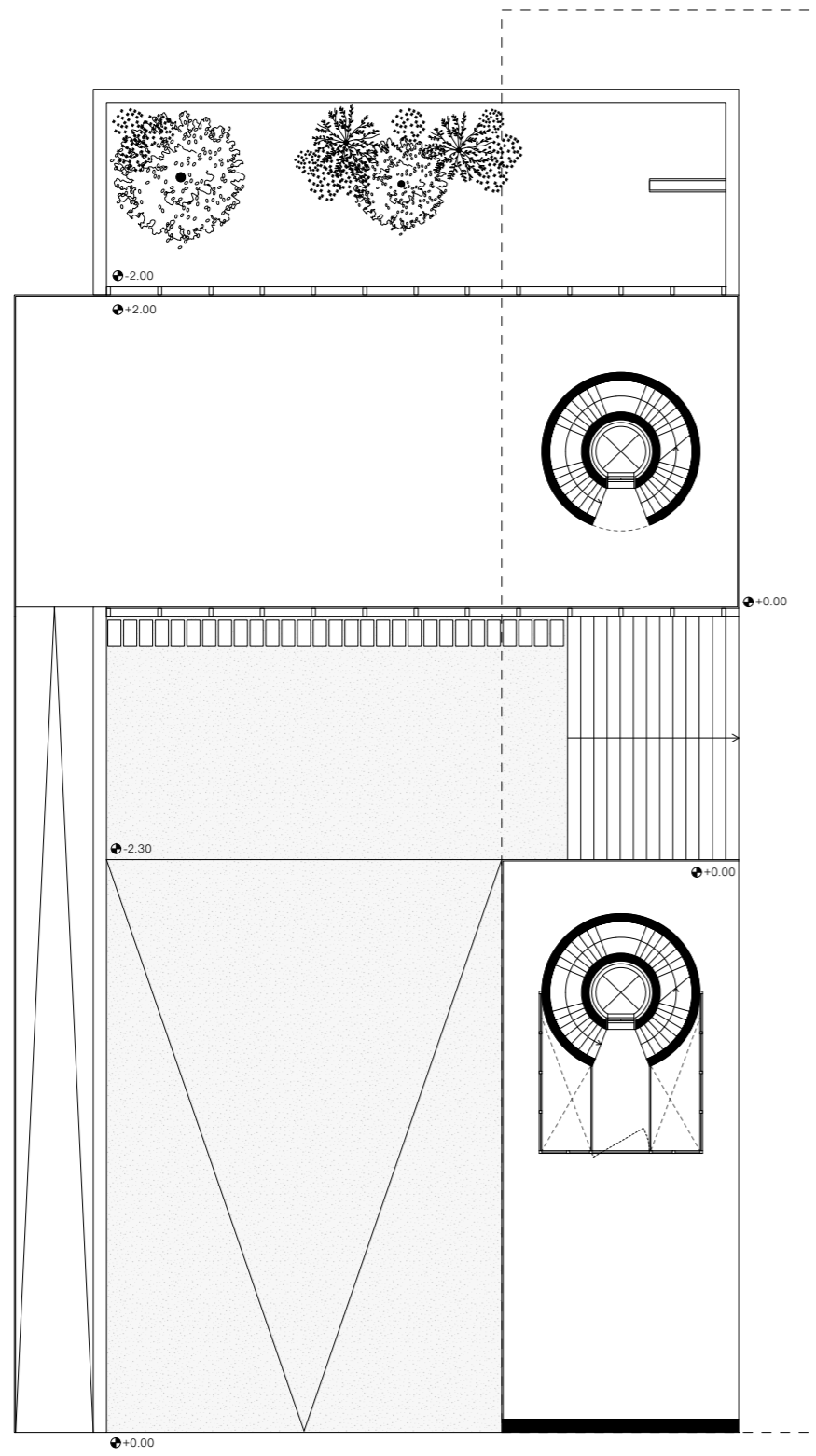

ground floor plan



160 161



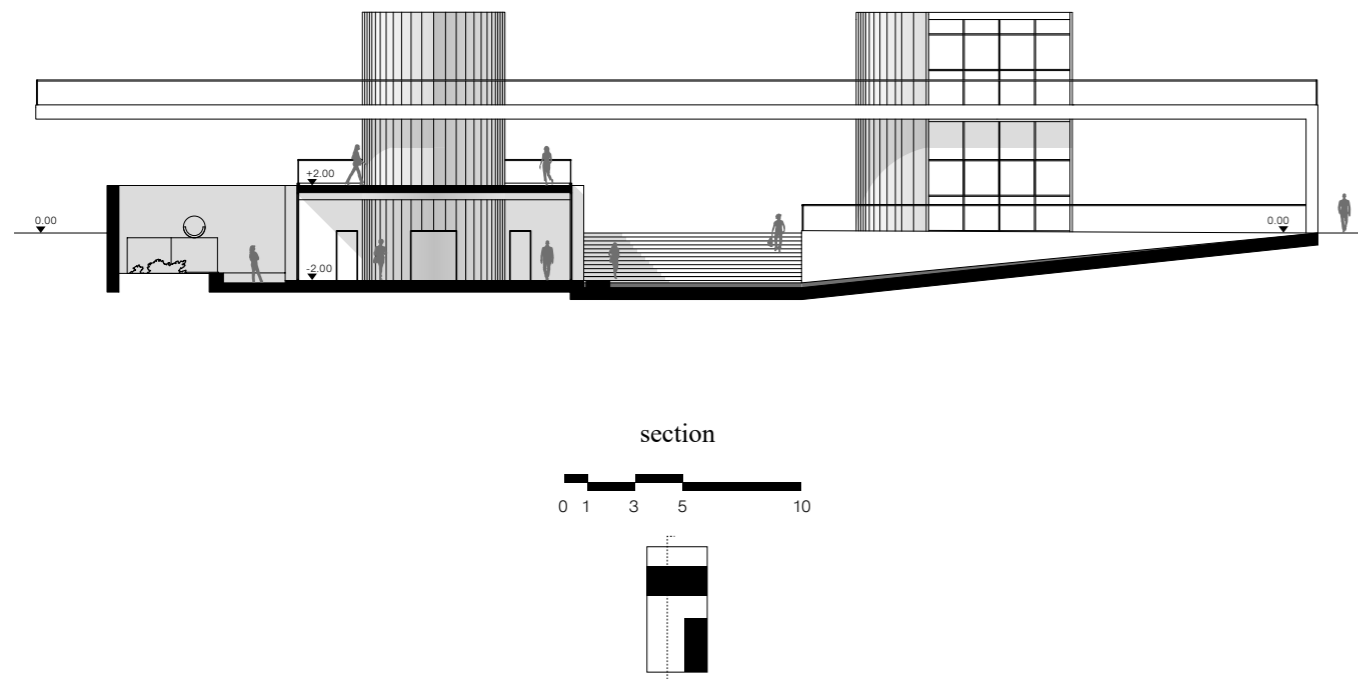
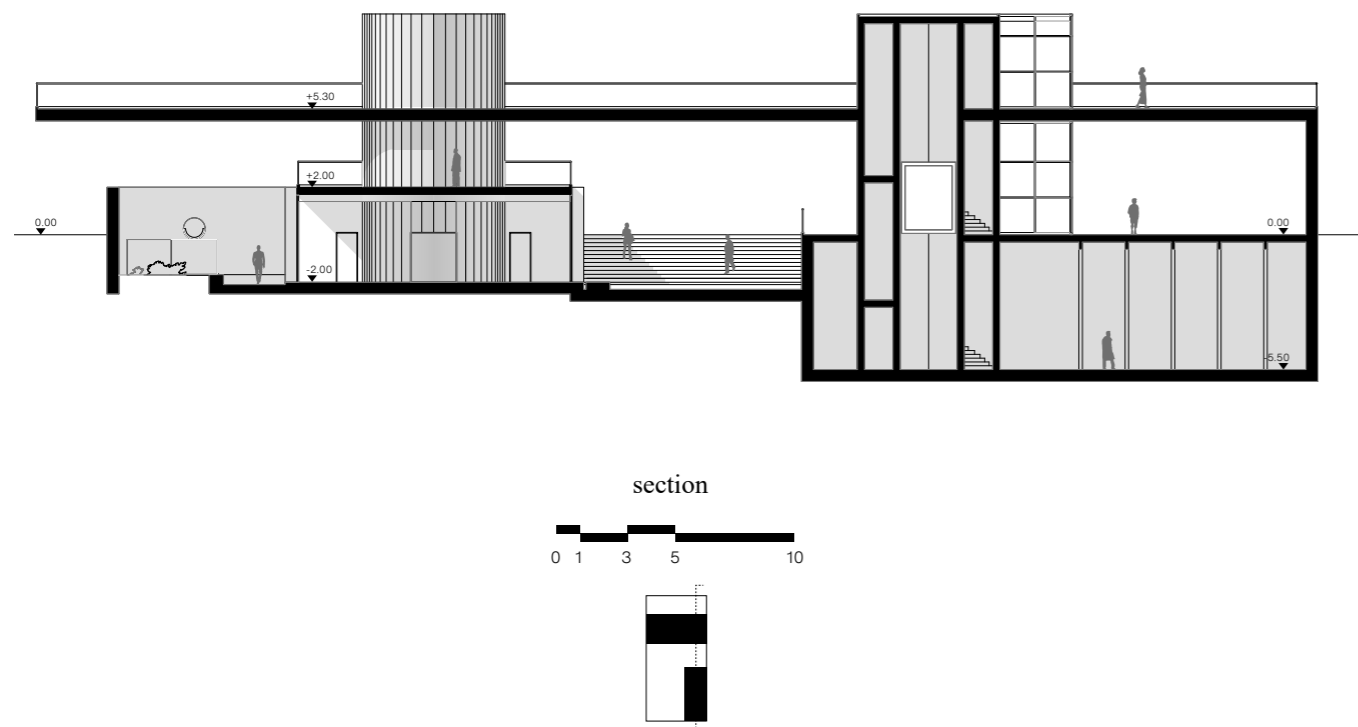

the relief you feel here in Scandinavia when after weeks of rain, clouds and darkness, you suddenly come through all this, out into the sunshine again... The second example from Mexico is Monte Alban, an ingeniously chosen site for devotion to the Gods. The human regulation or adaptation of the site has resulted in something even stronger than nature and has given it spiritual content. The little mountain, Monte Alban, almost a pyramid, dominates three valleys outside the town, Oaxaca, in Southern Mexico. The top of the pyramid is lacking and leaves a great flat part, approximately 500 metres to 300 metres. By the introduction of staircase arrangements and step-like buildings on the edge of the platform and keeping the central part at a lower level, the mountain top has been converted into a completely independent thing floating in the air, separated from the earth, and from **up there you see actually nothing but the sky and the passing clouds, – a new planet.**

162 163

PRESENCE, The Brickmaker's Tale: Maker's stamps on metal, wood, and clay evince a second category of material consciousness. The maker leaves a personal mark of his or her presence on the object. In the history of craftsmanship, these maker's marks usually have carried no political message, as a graffiti scrawled on a wall can, merely the statement anonymous laborers have imposed on inert materials, **fecit: "I made this," "I am here, in this work," which is to say, "I exist."** The philosopher Anne Phillips would not scorn such a declaration as part of what she calls "the politics of presence," nor have historians of the labors and maker's marks of American slaves. Ancient brick stamps also bore this primal message, but to understand it requires understanding bricks themselves in some detail.

Mud bricks have been used in construction for nearly ten thousand years. Archaeologists have found pure-clay bricks of this age in the city of Jericho, and adobe bricks clay tempered with straw or manure in the same city dating from about 7600 BCE. Sun-fired bricks formed in molds are cheap and quick to make but are at the mercy of the weather, often degrading in prolonged rain. The invention of fired brick about 3500 BCE marked a turning point in brick

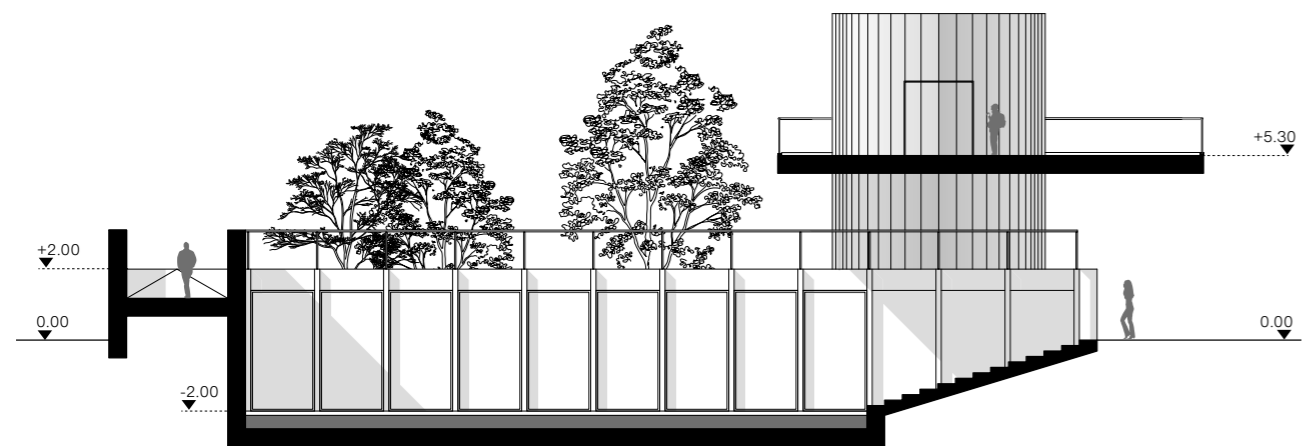

164 165

section

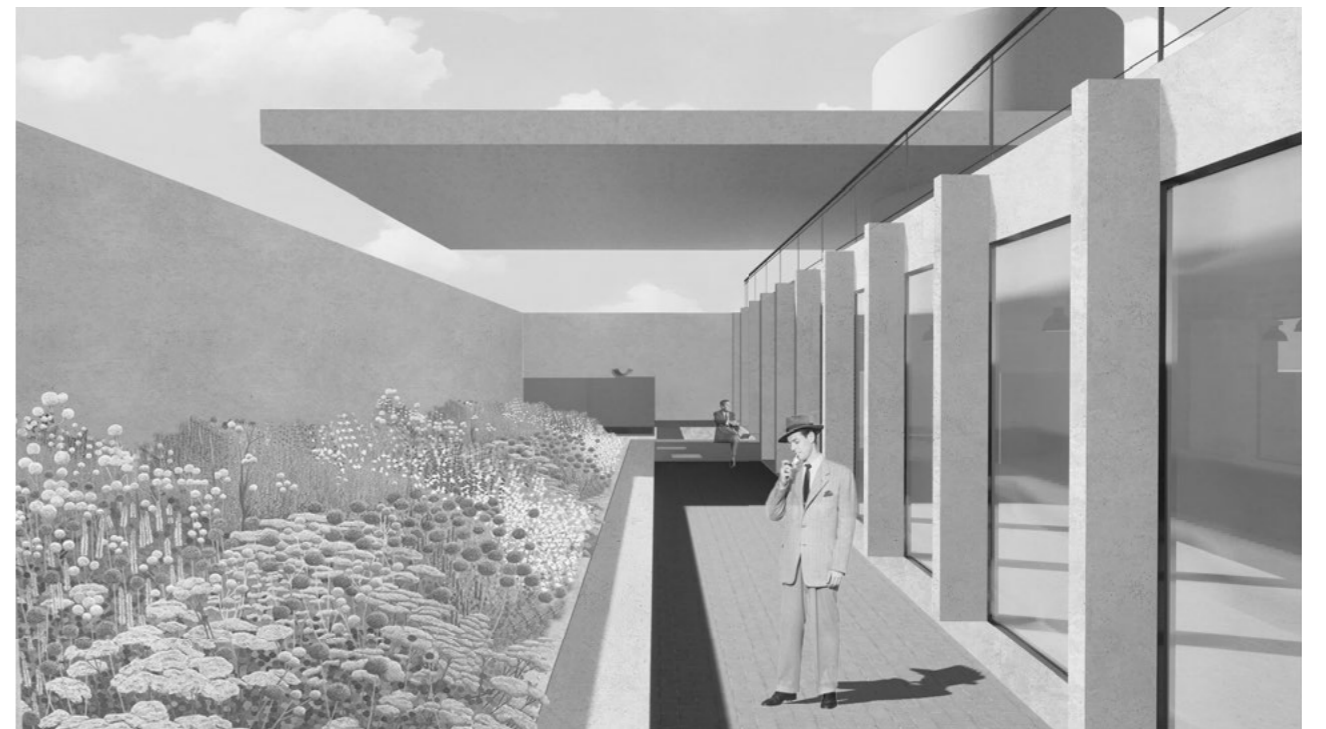
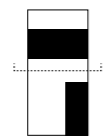

atmosphere

construction, the blocks now strong in all seasons, serviceable in variety of climates. The invention of fired brick was inseparable from the invention of the oven; some evidence suggests that the same enclosures were first used for both cooking and constructing. In cooking bricks, the kiln walls do work no open-air fire could. Even within the earliest known kilns, temperatures could rise well above 1000 degrees Celsius. Brick composed of 50 percent clay require from eight to fifteen hours of heat at this temperature and an equal time to cool slowly in order not to crack. The character of brick varies in the amount of clay it holds. Unbaked mud bricks are usually composed of less than 30 percent clay; at the other, baked extreme, terracotta brick is usually about 75 percent clay. Sand, straw, and water bulk up the clay, but in fired brick, stone must be excluded from or crushed into the mix, because stone can explode in the high heat of a kiln.

The brick, small and portable, radically influenced both the shape and the texture of large buildings. Egyptians at least since 3000 BCE contrived arches and vaults with fired bricks, thus adding curves to the right-angle beam-and-lintel system of more primitive structures. The Mesopotamians became masters of glazing and painting brick, so that permanent color became a feature of walls...

The long history of crafting clay shows three ways of becoming aroused consciously by materials, in altering, marking, or identifying them with ourselves. Each act has a rich inner structure: metamorphosis can occur through development of a type-form, combination of forms, or domain shift. **Marking an object can be a political act, not in the programmatic sense, but in the more fundamental matter of establishing one's presence, objectively.** Anthropomorphosis reveals the power of metaphor and a technique for manufacturing symbols. In the history of clayware, none of these three processes proved as simple as these summary labels might suggest. The worker in clay coped slowly with technical change, with political oppression rendering him or her invisible, and with the clash of human attributes. We could of course treat clay simply as a material that is necessary for cooking and for shelter. But in this utilitarian spirit we would eliminate most of what has made this substance culturally consequent.

166 167

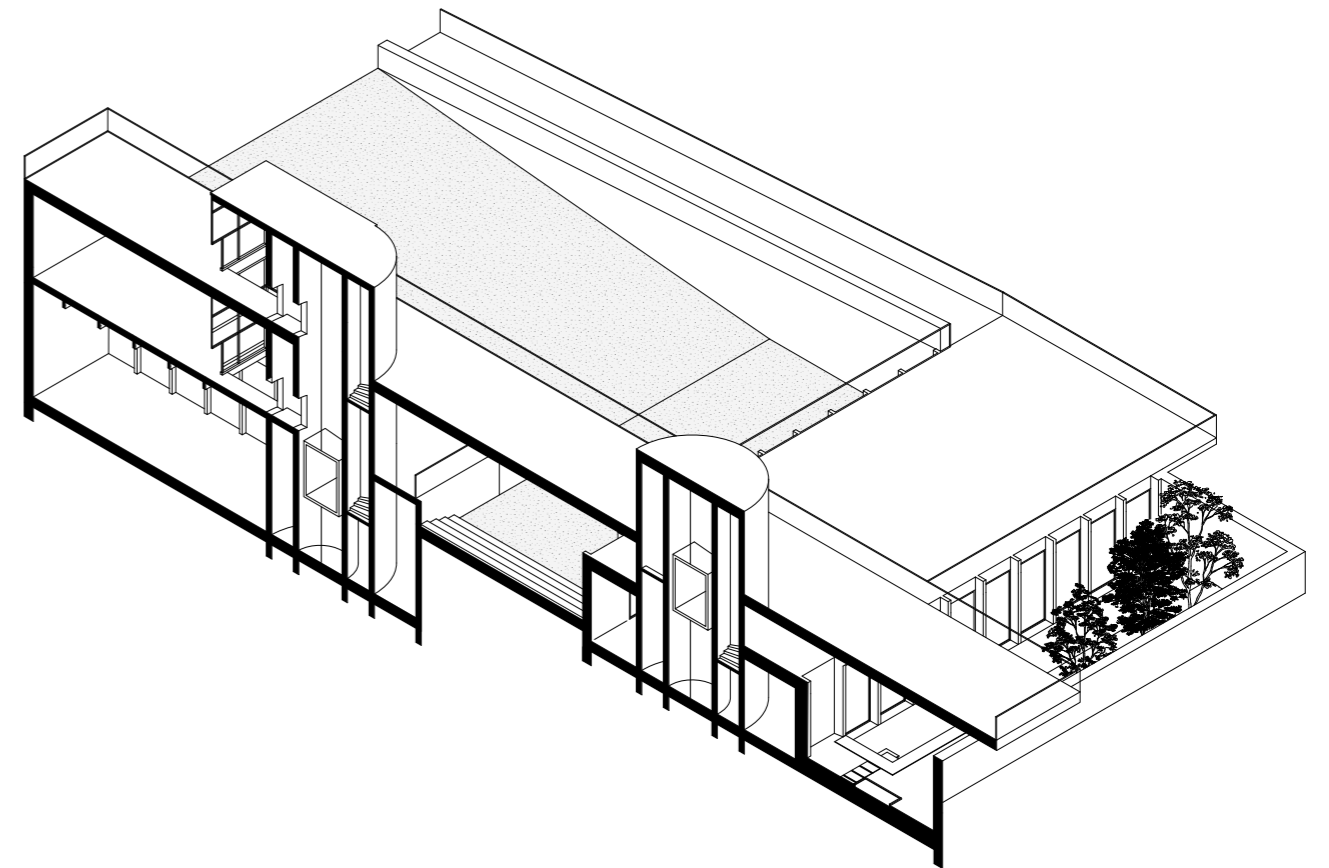

axonometry

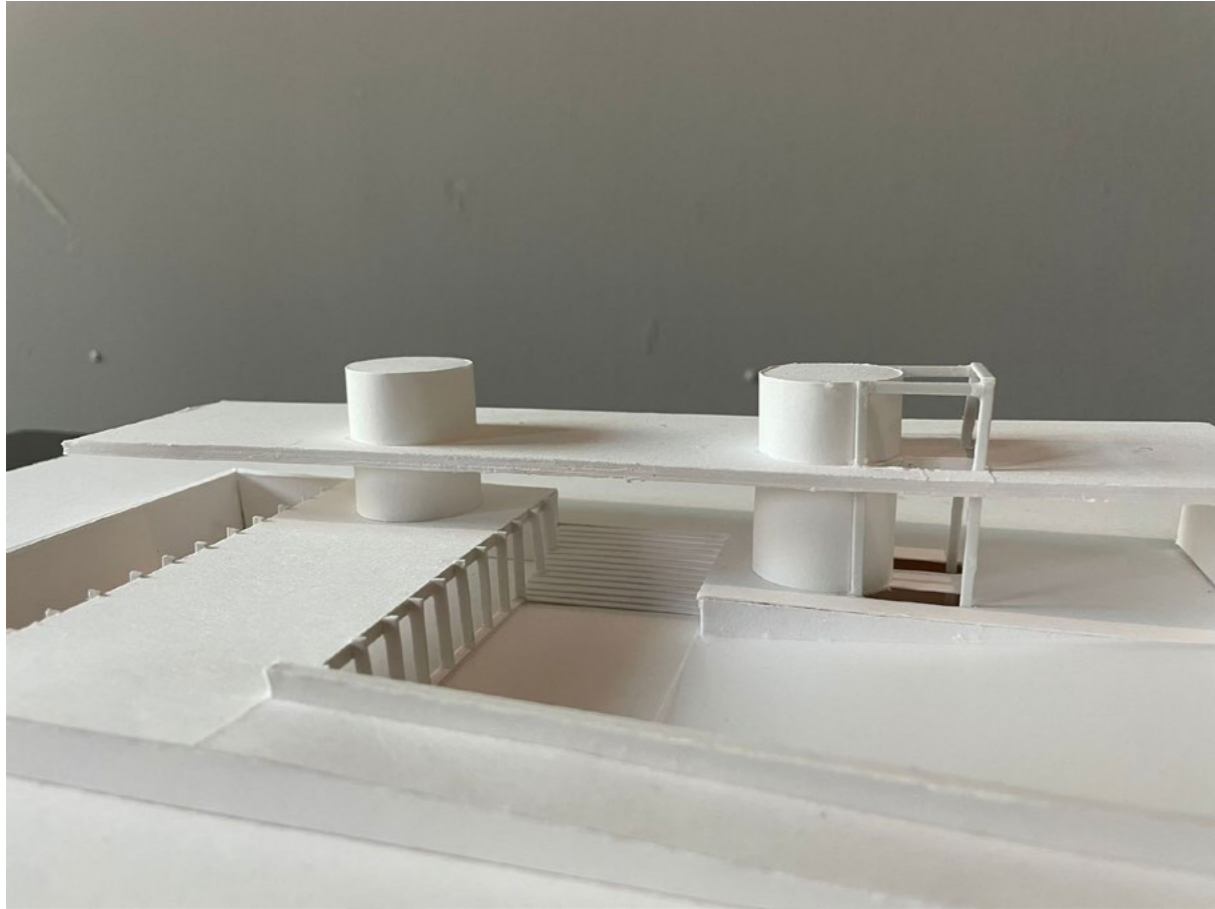

168 169





Maria Gaia Cicconi / Marco Frassetto



Maria Gaia Cicconi / Marco Frassetto

The Marseilles structure is all concrete - concrete in its crudest, most brutal form, béton brut! Concrete poured into the simplest form work, to come out looking as rough and virile as rock, deliberately chipped and cracked, full of pebble surfaces here and sea-shell surfaces there, as beautifully textured as the now blackened travertine of the great Roman ruins of Italy and southern France. Next to the Marseilles building, Lever House would look like the latest Cadillac – slick, thin-shelled, soon out of date. Next to the Marseilles building, every other modern “curtain wall” structure would look as tinny as an oil can, and sure to rust away just as fast. For this massive piece of brute concrete could be of any time: it could be an Egyptian temple of 2000 B.C., or a vision of the twenty-first century.

... There was a great celebration on the Marseilles roof when the building “officially” opened, at a CIAM party on a summer evening in 1953. Architects from every part of the world attended, including Corbu’s old associate from the days in Behrens’s office, Walter Gropius, who had by this time become the principal apostle of Machine Art architecture in the United States. Yet Gropius recognized at once that Corbu had created an entirely new architectural vocabulary. **“Any architect who does not find this building beautiful,”** Gropius said on that evening, **“had better lay down his pencil.”**

The actual value of the works shown to you I see not so much in the degree of achievement, as in the particular manner of form-giving. Nothing illuminates more clearly the situation in which we find ourselves than the fact that Ford's book could trigger such a strong reaction here in Germany. What Ford wants is simple and illuminating. His factories show mechanization in dizzying perfection. We agree with the direction Ford has taken, but we reject the plane on which he moves. Mechanization can never be goal, it must remain means. Means toward a spiritual purpose.

172 173

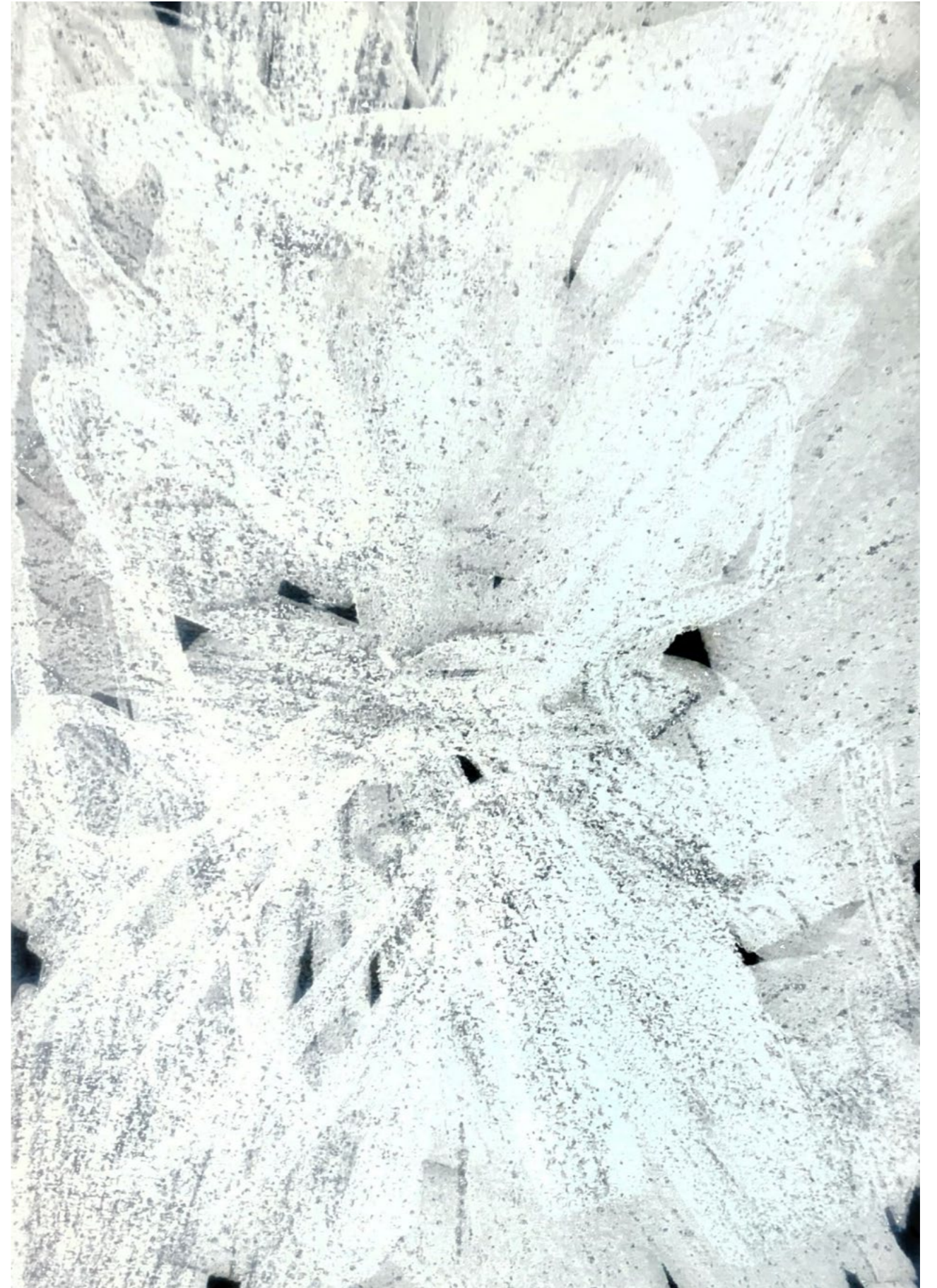



174 175





Maria Gaia Cicconi / Marco Frassetto

176 177

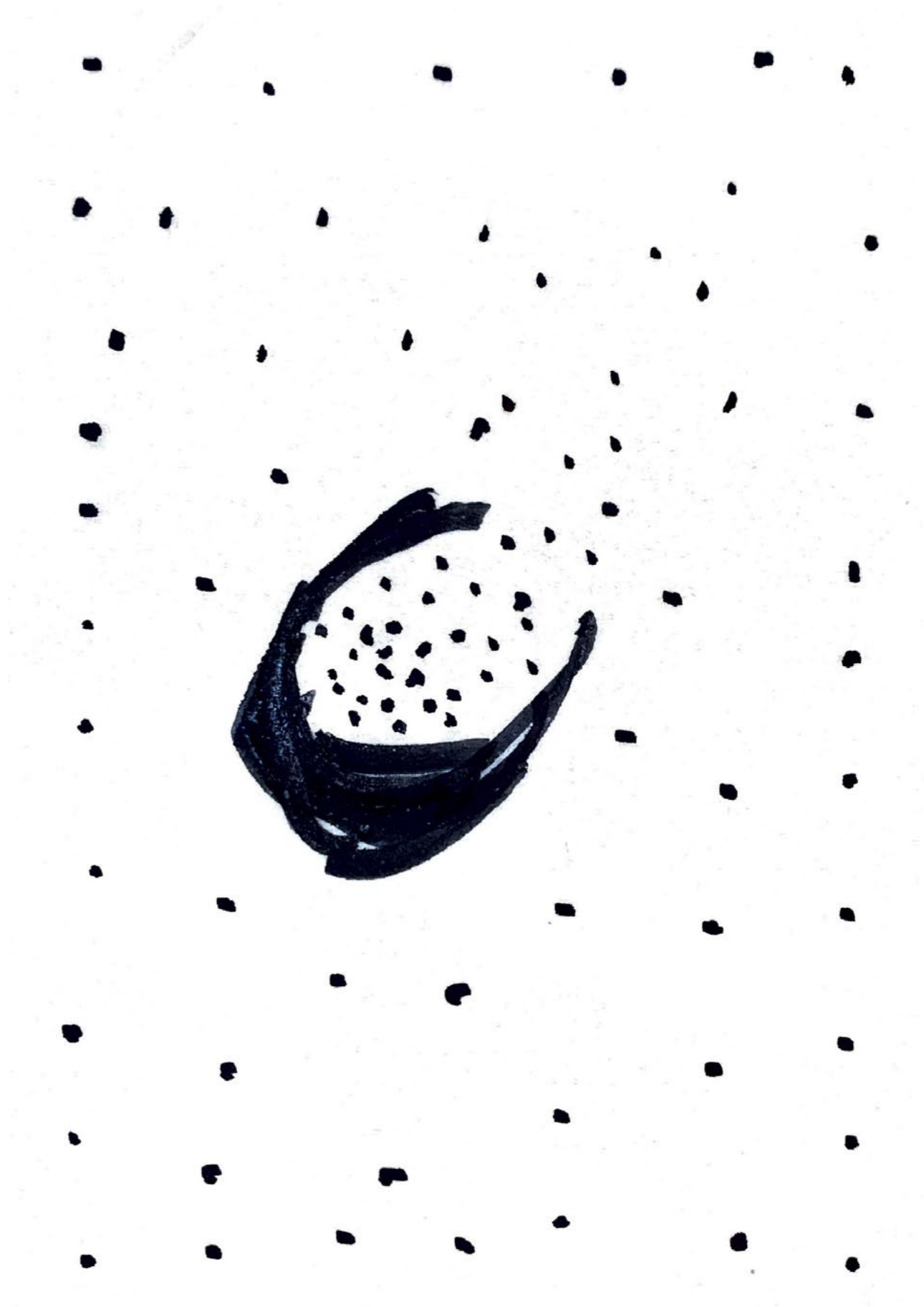

Maria Gaia Cicconi / Marco Frassetto

While we want to stand with both feet firmly on the ground, we want to reach with our heads to the clouds.

To grasp a beautiful thing or some difficult idea – the language clearly pronounces the hand – to – mind connection...

The way of looking, the way of drawing, and the way of thinking are causally related. The way of looking at things around us reflects our understanding of the world, the Universe, the nature we inhabit and the artificial things we produce from the natural things at our disposal – the buildings i.e. the actual architecture...

The project as an abstract entity is similar to Plato's form; discovered rather than created by us, non-imitative like a musical notation. As a thing itself, it is similar to Alberti's projection window – a set of projected images and texts. Immaterial apart the ink, it is the definition of the future presence of things into the visible world, closest possible to their actual material presence. Apart from this inherent thingness, the real building in the real place has always been the final cause of every project. Except in the end-product, be it the actual building or the ink on paper if the act of building never takes place, the decisive looking – drawing – building relation remains documented in writings, images and things we intentionally or non-intentionally discover, touch and produce before, during or after the work on our projects, connected to the solutions of actual problems or seemingly by accident while traveling real or fanciful spaces, libraries and collections.

Ordered in the logical sequence or placed within the actual space, those **words, images and things** may transcend their originally auxiliary purpose and become instrumental in the explanation of the marginal conditions of the project, expanding its scope and reference – the project domain as it were.

In our contemporary world of perpetual events, architecture remains a finite spatial experience. It requires close contact, it must be felt and touched without any intermediate filters. As such, it cannot be produced in void or taught from distance. Architecture is eminently thingly. Even our (digital) drawings alone have their own

178 179

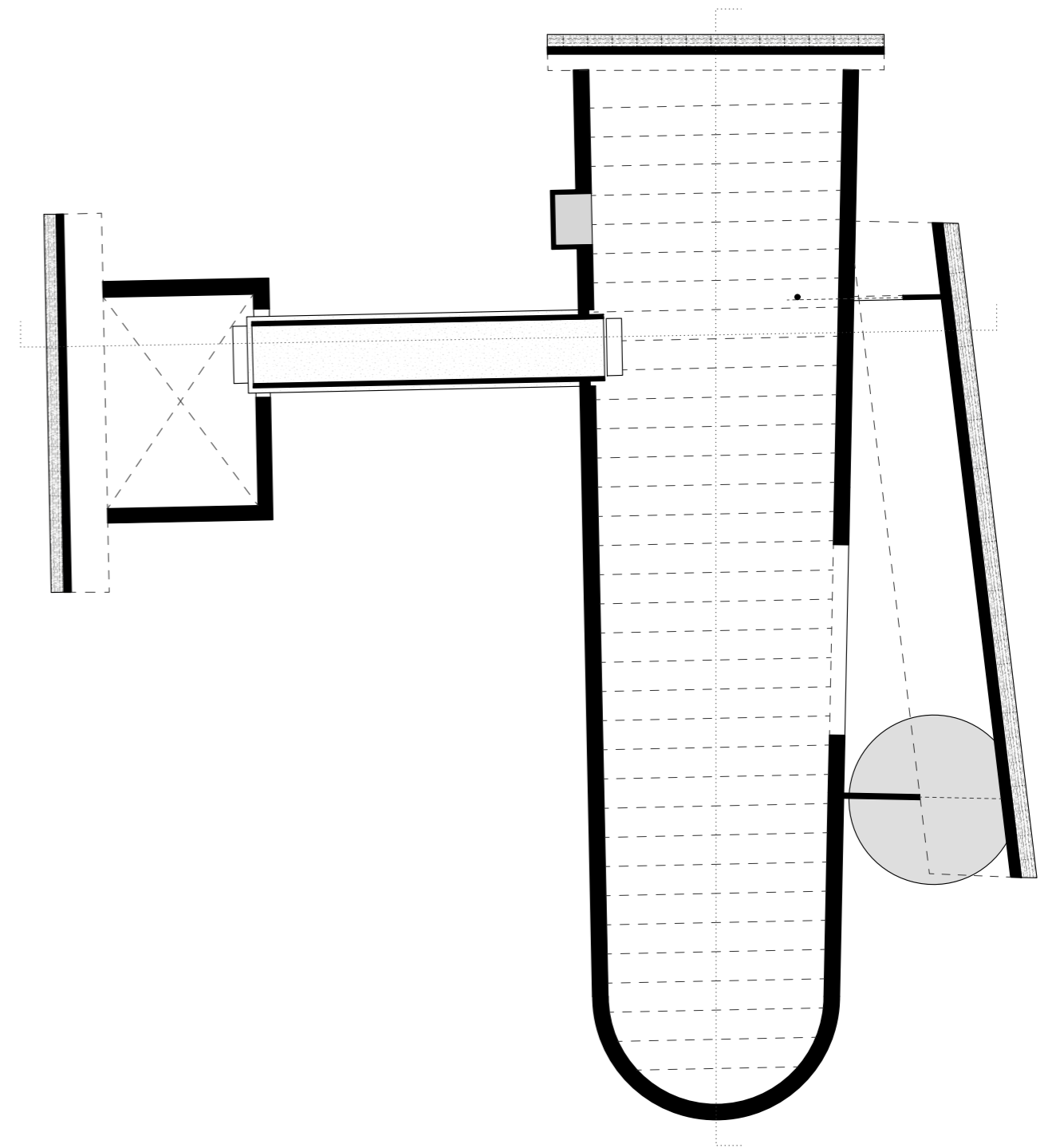

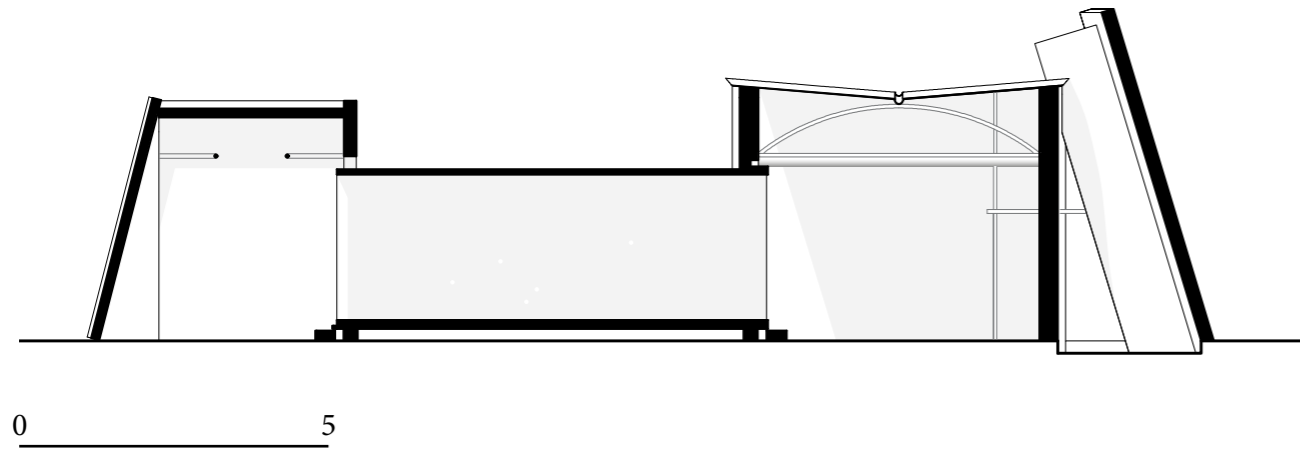

180 181

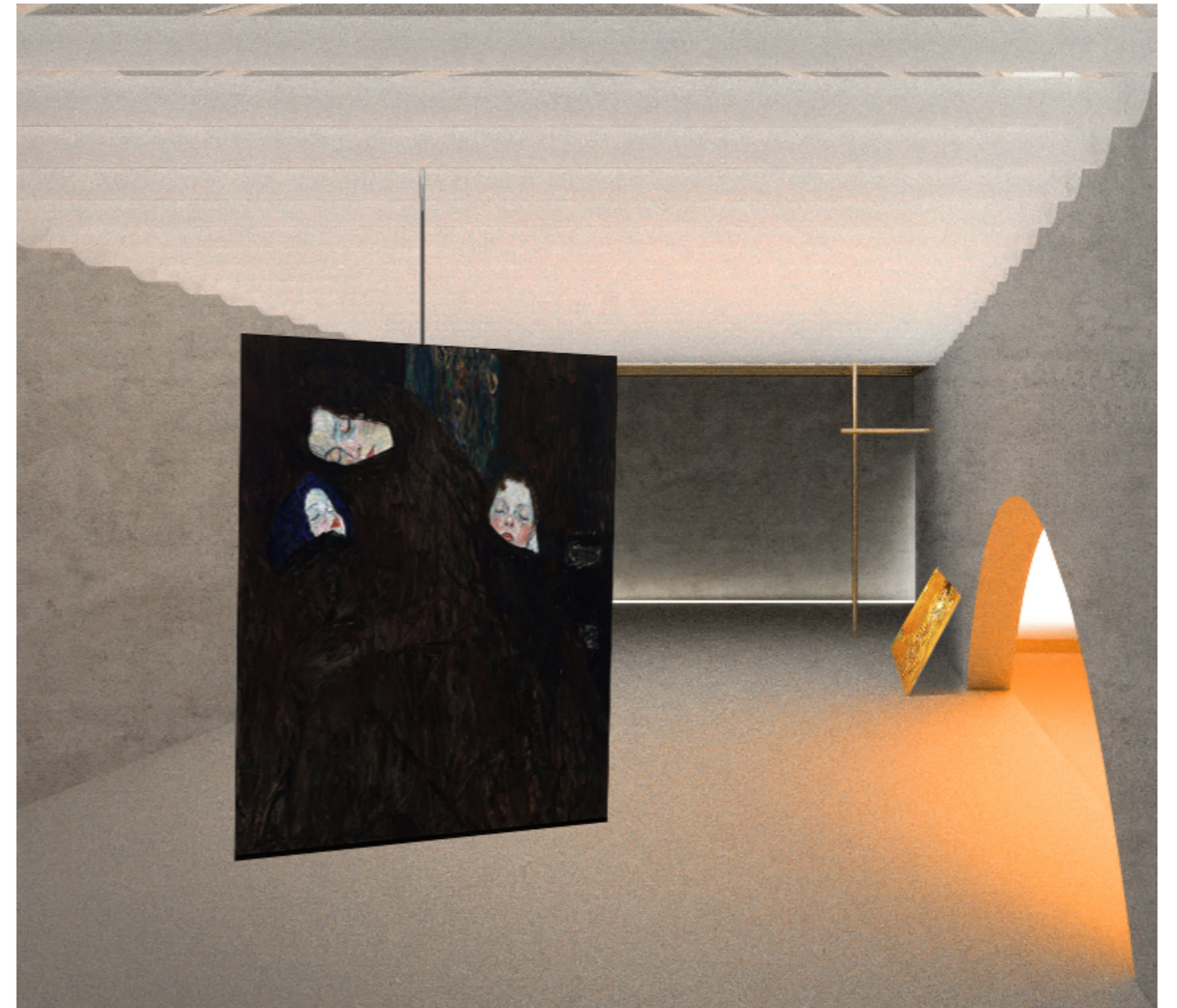
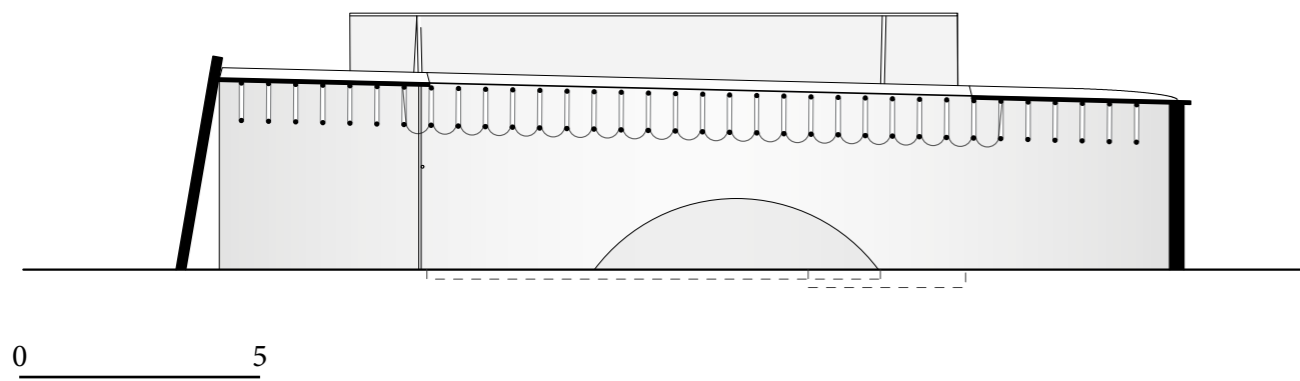

distinct thingness. Firmly anchored in the world of things, a thing itself made of things, every work of architecture is in opposition to the emergent world of events.

In Kepler's beautiful vision of the outer space, the planetary orbits did not simply occur in a dark void governed by mysterious gravitation forces. They are the consequence of the immaterial *species* which the solar body emanates rotating as if on a lathe, analogous to the immaterial *species* of its light. Rotating itself, this *species* carries the bodies of the planets with its strong grasp. This Latin word related to the verb *specio* has an extraordinary wide range of meanings. It is also the Latin equivalent of the Greek εἶδος, Plato's word for his *forms* or *ideas*. The translator of *Astronomia Nova* chooses to leave this word untranslated since there is no English word that can embrace so many meanings. Kepler illustrated the movement of planets in the outer space with the circular river paradigm and sailor revolving his oar through the aethereal air, reminiscent of the ancient Egyptian vision of the celestial dome as the goddess Nut dressed in stars and water.

Brought down to earth into the Danae's chamber, architectural space first appeared as something similar to aether, something more than the volume of air enclosed within a chamber without windows and lit from above. It is also **the *species* – form, image, appearance, kind, property, quality, type, surface, semblance, emanation, spectacle, atmosphere** – of the actual building – the quintessence and the **THINGNESS OF ARCHITECTURE**.

182 183

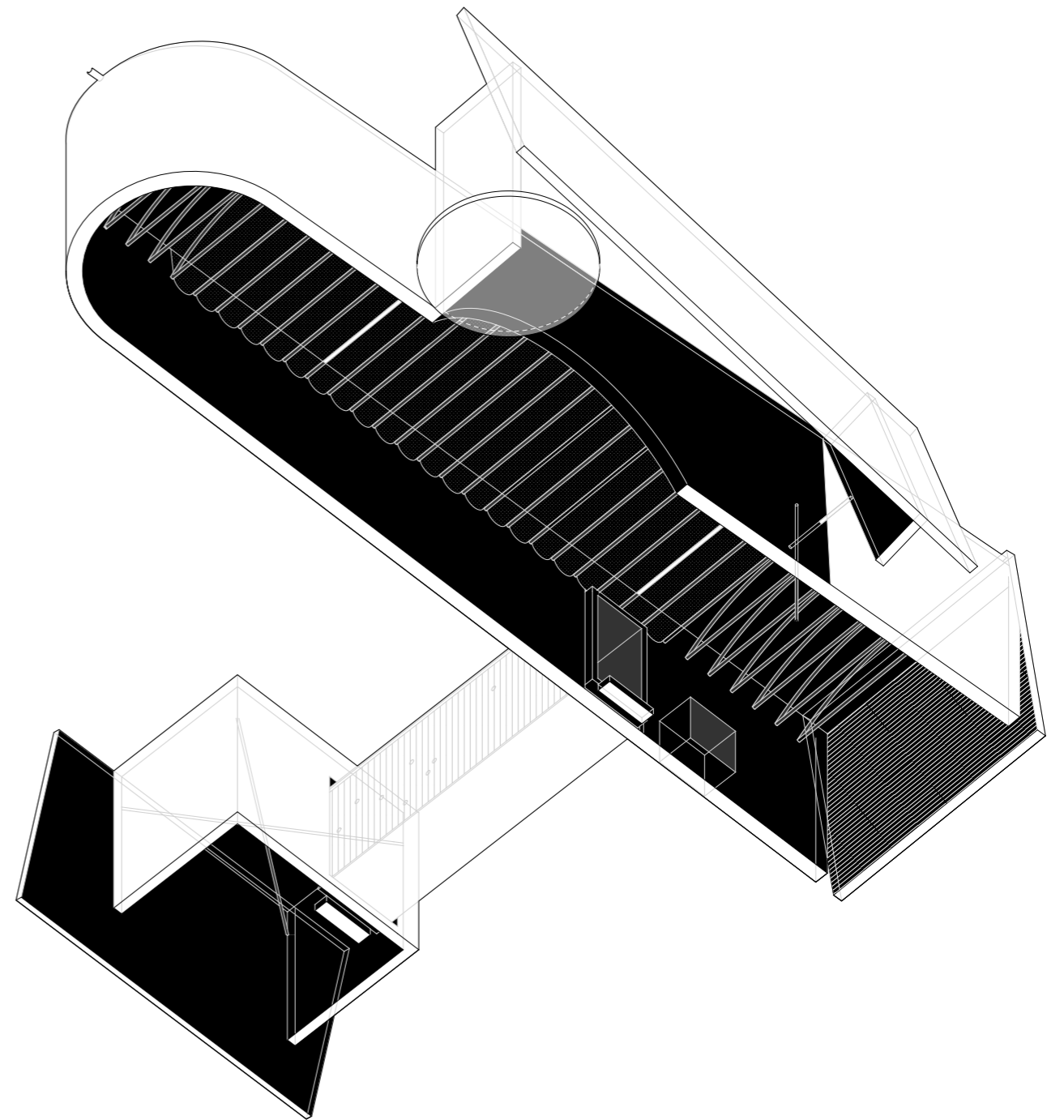



184 185



Maria Gaia Cicconi / Marco Frassetto

Maria Gaia Cicconi / Marco Frassetto



186 187



Excerpts from—

Fyodor Mikhailovich Dostoevsky, *Winter Notes on Summer Impressions*, 1862, translated by Kyril Fitzlyon, 1955. Richmond: Alma Books, 2016: 50-51

Louis I. Kahn, *Space and the Inspirations*, speech at the Conservatory Redefined Symposium, New England Conservatory, November 14th 1967. *L'architecture d'aujourd'hui* no.142: LOUIS.I.KHAN (1969):1-10

Ludwig Mies van der Rohe, *Address to the Illinois Institute of Technology*, 1950; *Inaugural Address as Director of Architecture at Armour Institute of Technology*, 1938; in Philip Johnson, *Mies van der Rohe*. New York: Museum of Modern Art, 1978: 203, 196-200

Vitruvius, *The Ten Books on Architecture: Book II, Chapter I*, transl. by Morris Hicky Morgan. Harvard University Press, 1914

Gottfried Semper, *The Four Elements of Architecture*, 1815, translated by Harry Francis Mallgrave and Wolfgang Herrmann. Cambridge: Cambridge University Press, 2011: 101-104

Plato, *The Republic: Book VII*, around 360 BC, translated by Benjamin Jowett, classics.mit.edu

Martin Heidegger, *The Origin of the Work of Art*, 1936-1960, translated by Roger Berkowitz and Philippe Nonet, draft: 24-40, academia.edu

Henry Miller, *The Colossus of Maroussi*, 1941. New York: New Directions, 1958

Reyner Banham, *The Wilderness Years of Frank Lloyd Wright*, 1969; in Mary Banham, Paul Barker, Sutherland Lyall, Cedric Price (eds.), *A Critic Writes: Essays by Reyner Banham*. Berkeley and Los Angeles: University of California Press, 1996: 137-151

Le Corbusier, *Journey to the East*, 1965 (1911); translated by Ivan Žaknić. Cambridge Massachusetts: The MIT Press, 1987

Wim Wenders, *Once*, 1994, translated by Marion Kagerer. München: Schirmer / Mosel, 2011: 7-15, 254-297

Hans Sedlmayr, *Art in Crisis: The Lost Center*, 1948, transl. by Roger Kimball. New Brunswick and London: Tr. Publishers, 2009

Robert Smithson, *A Tour of the Monuments of Passaic*, New Jersey, 1967; in Jack Flamm (ed.), *Robert Smithson: The Collected Writings*. Berkeley and Los Angeles: University of California Press, 1996: 68-74

John Ruskin, *The Seven Lamps of Architecture: Lamp of Power*, 1849; in Joan Evans (ed.), *John Ruskin, The Lamp of Beauty: Writings on Art*. London: Phaidon, 1995: 208-213

Ayn Rand, *The Fountainhead*, 1943. New York: Signet, 1996

Curzio Malaparte, *The Skin*, 1949, translated by David Moore. Evanston, Illinois: Northwestern University Press, 1977: 203-205

Jean-Luc Goddard, *Le Mépris*, manuscript, 1963. Paris: Edit. de Saint-Pères, 2013: 67-78

Le Corbusier, *Mise au point*, 1965. douban.com/note/270502179/

Jørn Utzon, *Platforms and Plateaus: Ideas of a Danish Architect*. Zodiac (Milano), 10(1963): 110-117

Richard Sennett, *The Craftsmen*, chapter 4: *Material Consciousness*. London: Allen Lane, 2008: 119-146

Peter Blake, *The Master Builders: Le Corbusier and the Mastery of Form*, 1960. New York and London: W. W. Norton & Company, 1996: 117-124

Ludwig Mies van der Rohe, *Notes for a lecture*, June 19th 1924; in Fritz Neumeyer, *The Artless World: Mies van der Rohe on the Building Art*, translated by Mark Jazombrek. Cambridge Massachusetts: MIT Press, 1991: 249-250

Krunoslav Ivanišin, *Projects and Things*; in Krunoslav Ivanišin, Lulzim Kabashi, Zvonimir Prusina, IVANIŠIN. KABASHI. ARHITEKTI: *Projects and Things*. Zagreb: Oris House of Architecture, 2021





192 193

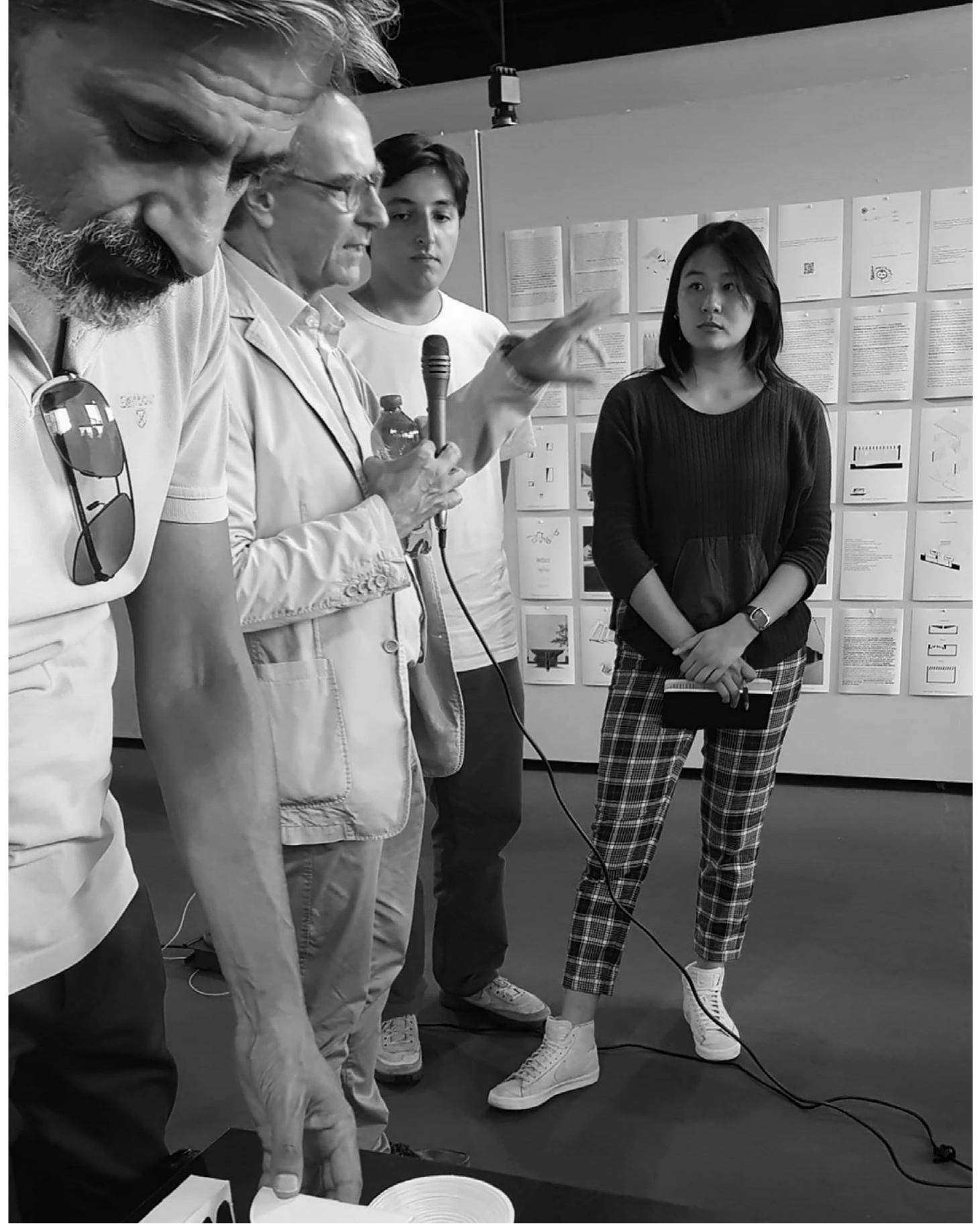

Place

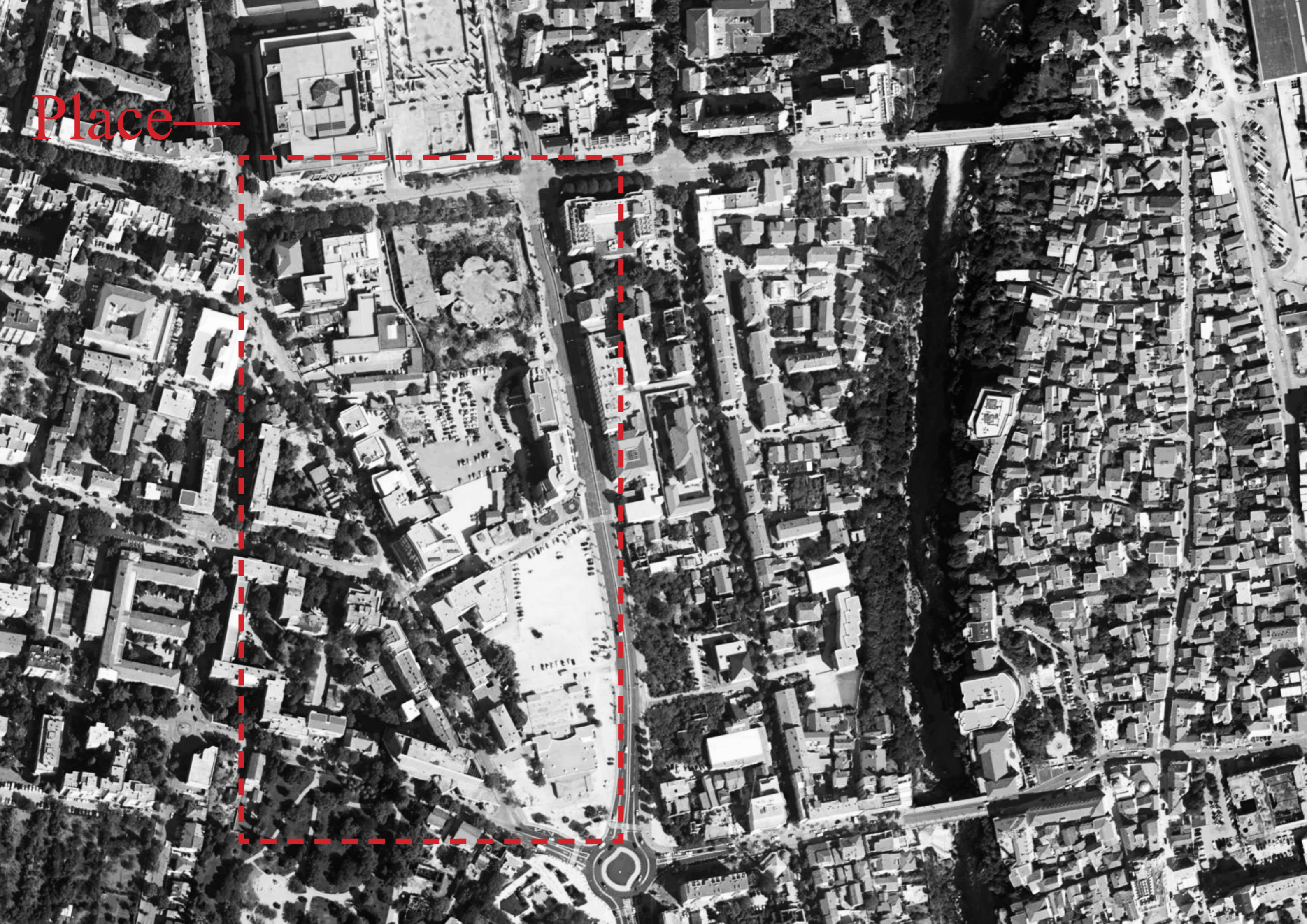





198 199





200 201





SEPTEMBER, 2023

booklet design

Zvonimir Prusina

09—2023